

**THE NATURAL RESOURCES  
CONSERVATION (WASTEWATER  
AND SLUDGE) REGULATIONS,  
2013**

**GUIDELINE FOR LICENSEES**

March 2014

*Note* These guidelines have been prepared by the National Environment and Planning Agency (NEPA) in good faith exercising all due care and attention, but no representation or warranty, expressed or implied, is made as to the relevance, accuracy, completeness or fitness of this document for any other purpose in respect of a particular user's circumstances. Users of this document should satisfy themselves about its application to their situation and, where necessary, seek expert advice.

Copies may be obtained from the website of the National Environment and Planning Agency <http://www.nepa.gov.jm> or the Documentation Centre, NEPA, 11 Caledonia Avenue, Kingston 5, Jamaica W. I. Telephone: (876) 754 7540 Email: [docentre@nepa.gov.jm](mailto:docentre@nepa.gov.jm).

*The guidelines will be revised periodically following feedback from stakeholders using it, ensuring its ongoing relevance and reflecting advances in best practice as the result of regulator and industry experience. Comments are invited and should be sent via email to [pubed@nepa.gov.jm](mailto:pubed@nepa.gov.jm).*

National Environment and Planning Agency  
10 and 11 Caledonia Avenue  
Kingston 5  
Jamaica W. I.  
Telephone: (876) 754 7540  
Facsimile: (876) 754 7595  
Email: [pubed@nepa.gov.jm](mailto:pubed@nepa.gov.jm)

March 2014

# TABLE OF CONTENTS

<b>TABLE OF CONTENTS</b> .....	<b>iii</b>
<b>ACRONYMS</b> .....	<b>viii</b>
<b>1. INTRODUCTION</b> .....	<b>10</b>
<b>1.1 Scope of the Guideline</b> .....	<b>10</b>
<b>2. OVERVIEW OF THE MAIN FEATURES OF THE WASTEWATER AND SLUDGE REGULATIONS</b> .....	<b>12</b>
<b>2.1 Rationale for Regulations</b> .....	<b>12</b>
<b>2.2 Scope of the Regulations</b> .....	<b>13</b>
2.2.1 Facilities to be Licensed .....	14
2.2.2 Discharge of Trade or Sewage Effluent into a Sewage Collection System or Treatment Plant (Regulations 8, 9 and 10) .....	16
<b>2.3 Regulatory Agencies</b> .....	<b>17</b>
<b>2.4 Structure of the Regulations</b> .....	<b>17</b>
<b>3. APPLYING FOR LICENCES AND REPORTING ACCORDING TO LICENCE REQUIREMENTS</b> .....	<b>21</b>
<b>3.1 Introduction to Environmental Licences</b> .....	<b>21</b>
<b>3.2 Specifications for the Issuing of Licences</b> .....	<b>21</b>
<b>3.3 Licence Application Process (Regulations 5, 6, 7 and 12)</b> .....	<b>22</b>
3.3.1 Completing the Licence Application Form (First Schedule) .....	22
3.3.2 Use of Marine Outfalls and Outfall Pipelines (Regulation 23) .....	27
<b>3.4 Discharge of Trade or Sewage Effluent into a Sewage Collection System or Treatment Plant (Regulations 8, 9 and 10)</b> .....	<b>28</b>
<b>3.5 Preparation of Compliance Plans (Regulation 40)</b> .....	<b>28</b>
<b>3.6 Preparation of Nutrient Management Plans (Regulation 26)</b> .....	<b>33</b>
<b>3.7 Preparation of Wastewater Treatment Plants Operations and Maintenance Manual (Regulation 20)</b> .....	<b>37</b>
<b>3.8 Preparation of Monitoring Reports (Regulation 25)</b> .....	<b>41</b>
3.8.1 Preparation of Periodic Reports (daily, weekly, monthly or quarterly) For Sewage Treatment Plants .....	42
3.8.2 Preparation and Submission of Monitoring (Weekly, Monthly, Quarterly) Reports for Trade Effluent (Fourth Schedule: Form 2) .....	43

3.8.3	Preparation of Annual Sewage Effluent Reporting Form, (Fourth Schedule Form 3) .....	47
3.8.4	Preparation of Annual Trade Effluent Reporting Form (Fourth Schedule: Form 4).....	49
3.8.5	Form to Report Spills and Pollution Incidents (Fourth Schedule: Form 5) .....	51
3.8.6	Preparation of Quarterly and Annual Industrial Sludge Reporting Form (Schedule Four: Form 6) .....	52
<b>3.9</b>	<b>Pollutant Release and Transfer Register (PRTR) Facility Reporting (Regulation 46) .....</b>	<b>55</b>
<b>4.</b>	<b>SLUDGE MANAGEMENT .....</b>	<b>57</b>
<b>4.1</b>	<b>Beneficial Use of Sludge .....</b>	<b>57</b>
<b>4.2</b>	<b>Management at Waste Water Treatment Plant Sites .....</b>	<b>59</b>
<b>4.3</b>	<b>Disposal to Landfill .....</b>	<b>59</b>
<b>4.4</b>	<b>Transportation .....</b>	<b>61</b>
<b>5.</b>	<b>MONITORING.....</b>	<b>62</b>
<b>5.1</b>	<b>Introduction to Wastewater Monitoring.....</b>	<b>62</b>
<b>5.2</b>	<b>Sampling Schedule and Frequency.....</b>	<b>62</b>
<b>5.3</b>	<b>Sample Collection and Preservation.....</b>	<b>66</b>
<b>5.4</b>	<b>Analytical Methods .....</b>	<b>66</b>
5.4.1	Record Keeping .....	67
<b>5.5</b>	<b>Flow Measurement.....</b>	<b>69</b>
5.5.1	Methods for measuring waste water flows.....	70
5.5.2	Inspection of Flow Measuring Devices.....	77
<b>5.5.2.1</b>	<b>Additional Information Sources .....</b>	<b>78</b>
<b>5.6</b>	<b>Guidelines For Monitoring Industrial and Sewage Sludge .....</b>	<b>79</b>
5.6.1	Industrial Sludge .....	79
5.6.2	Sewage Sludge.....	80
<b>6.</b>	<b>ESTIMATING EFFLUENT LOADS AND DISCHARGE FEES .....</b>	<b>82</b>
<b>6.1</b>	<b>General Principles of Measuring Loads .....</b>	<b>82</b>
6.1.1	Using Lab Monitoring Results with Flow Rate Measurement .....	82
<b>6.2</b>	<b>Discharge Fees .....</b>	<b>83</b>
6.2.2	Receptor Factor .....	84

<b>6.3</b>	<b>Estimation of Discharge Fees (including incentives).....</b>	<b>86</b>
<b>7.</b>	<b>APPENDICES.....</b>	<b>90</b>
	<b>Appendix 1: ISIC Codes and Descriptions.....</b>	<b>91</b>
	<b>Appendix 3: Template of Overview Format for Pollutant Release and Transfer Register (PRTR) Facility Report .....</b>	<b>98</b>
	<b>Appendix 4: Template of Detailed PRTR Facility Report.....</b>	<b>108</b>
	<b>Appendix 5: Template of the Quarterly/Annual Industrial Sludge Report.....</b>	<b>115</b>
	<b>Appendix 6: Summary Table for Load Calculation.....</b>	<b>118</b>

**LIST OF TABLES**

Table 2-1	ISIC Codes for activities that are be required to obtain a Licence .....	15
Table 3-1	Requirements for completing Licence Application Form and preparing attachments.....	23
Table 3-2	Preparation of Compliance Plans.....	28
Table 3-3	Suggestions for determining the duration of compliance plans .....	33
Table 3-4	Requirements for prepating nutrient management plans .....	35
Table 3-5	Requirements for Preparation of Operations and Maintenance Manuals.....	38
Table 3-6	Requirements for preparing Periodic Reports for Sewage Treatment Plants.....	42
Table 3-7	Requirements for the Monitoring Reports for Trade Effluent.....	44
Table 3-8	Requirements for reporting on parameters specified in licence .....	44
Table 3-9	Requirements for Sampling and Testing .....	47
Table 3-10	Requirements for the Preparation of Annual Sewage Effluent Reporting Form .....	47
Table 3-11	Requirements for the Preparation of Annual Sewage Effluent Reporting Form .....	48
Table 3-12	Requirements for the Preparation of the Annual Trade Effluent Reporting Form .....	49
Table 3-13	Requirements for reporting on parameters measured in accordance with licence conditions .....	50
Table 3-14	Requirements for the Form to Report Spills and Pollution Incidents.....	51

Table 3-15	Requirements for the Preparation of the Quarterly and Annual Industrial Sludge Reporting Form.....	52
Table 4-1	National Treated Sewage Sludge Standards for Fully Treated Sewage Sludge that can be applied to Agricultural Land.....	57
Table 4-2	Standards for Soil Waste/Industrial Sludge Suitable for Landfill.....	60
Table 4-3	Standards for Soil Waste/Industrial Sludge Suitable for Landfill (based on Leachate quality test results) .....	60
Table 5-1	Sampling Frequency and Parameters to be Monitored by Sector.....	62
Table 5-2	Procedure For Missed Samples .....	65
Table 5-3	Sampling Containers, Preservation Techniques, and Holding Times.....	68
Table 6-1	Parameter Fees (Sixth Schedule of Regulations, Part B) .....	83
Table 6-2	Weighting Criteria .....	84
Table 6-3	Receptor Weight Relationship (Sixth Schedule of Regulations, Part D) .....	86
Table 7-1	Selected Four Digit ISIC Codes (those likely to be most relevant for these Regulations) .....	91

**LIST OF FIGURES**

Figure 2-1	Exemptions under the Wastewater and Sludge Regulations .....	14
Figure 5-1	Common Types of Sharp-Crested Weirs (From Appendix G, Supplemental Flow Measurement Information, NPDES Compliance Inspection Manual (1994)).....	72
Figure 5-2	Profile and Nomenclature of Sharp-Crested Weirs (From Appendix G, Supplemental Flow Measurement Information, NPDES Compliance Inspection Manual (1994)) .....	73
Figure 5-3	Manning Formula .....	75
Figure 5-4	Dimensions and Capacities of Parshall Measuring Flumes for Various Throat Widths (From Appendix G, Supplemental Flow Measurement Information, NPDES Compliance Inspection Manual (1994)) .....	76
Figure 5-5	Free Flowing Palmer Bowls Flume From Appendix G, Supplemental Flow Measurement Information, NPDES Compliance Inspection Manual (1994)) .....	77

**LIST OF BOXES**

Box 1	Sample Calculation 1- Direct measurement .....	82
Box 2	Sample Calculation 2 .....	88
Box 3	Sample Calculation 3 .....	88

# ACRONYMS

ASTM	American Society of Testing Materials
BOD	Biological Oxygen Demand
CAS	Chemical Abstracts Service
CEO	Chief Executive Officer
COD	Chemical Oxygen Demand
EA	Environmental Assessment
EHU	Environmental Health Unit
EIA	Environmental Impact Assessment
EPA	Environmental Protection Agency
F. Coli	Faecal Coliform
HVAC	Heating, ventilation and cooling
ISCO	Instrumentation Specialists Company
ISIC	International Standard Industrial Classification of all Economic Activities
KMR	Kingston Metropolitan Region
JMA	Jamaica Manufacturers Association
MSDS	Material Safety Data Sheet
NEPA	National Environment and Planning Agency
NEPIS	National Environmental Publications Information System
NMP	Nutrient Management Plan
NPDES	National Pollutant Discharge Elimination System
NRCA	Natural Resources Conservation Authority
NTIS	National Technical Information Service
NWC	National Water Commission



P&L	Permits and Licences
PMA	Pollution Monitoring and Assessment
PRTR	Pollutant Release and Transfer Register
PSOJ	Private Sector Organization of Jamaica
QA/QC	Quality Assurance/Quality Control
STATIN	Statistical Institute of Jamaica
STP	Sewage Treatment Plant
TDS	Total Dissolved Solids
TSS	Total Suspended Solids
WRA	Water Resources Authority
WSMU	Wastewater and Sludge Management Unit
WWSR	Wastewater and Sludge Regulations

# **1. INTRODUCTION**

The purpose of this Guideline is to provide assistance to licensees and prospective licensees to comply with the Natural Resources Conservations (Wastewater and Sludge) Regulations, 2013, hereafter referred to as “the Regulations”. This Guideline Document aims to assist licensees in determining when and how to apply for a licence, including the completion of application forms for licences and how to conduct the ongoing monitoring, reporting and other requirements or conditions specified in their licences.

Some aspects of the Guideline (such as sampling, analysis, quality assurance and quality control for effluent and other samples) may also be used by licensees and other groups to include consultants for studies that are required for regulatory or other purposes.

The ultimate goal of this Guideline is to enable transparent, consistent, efficient and objective enforcement of the Wastewater and Sludge Regulations by the use of consistent sampling, analysis, reporting and assessment procedures and the transparent and consistent review, evaluation and assessment of the information.

## **1.1 Scope of the Guideline**

The main focus of the Guideline is to provide licensees with information on the features and provisions in the Regulations and to provide them with guidance on carrying out activities needed to make applications for licences and to comply with the requirements of their licences. The topics include:

- a) information on who should apply for Licences (Section 2);
- b) information that the National Environment and Planning Agency (NEPA) will require from applicants for assessment and approval of licence applications (Section 3);
- c) description of the reporting system that includes requirements of the periodic and emergency reporting forms used in the Regulations and record keeping (Section 3);
- d) guidance on the preparation of Operations and Maintenance Plans (Section 3);
- e) methods for the sampling and analysis of wastewater (trade effluent, sewage effluent, industrial sludge and sewage sludge) for regulatory purposes (Section 5);
- f) guidance in the calculation of the load-based Discharge Fees and annual reporting (Section 6); and

g) additional information the NEPA will require in order to satisfy reporting requirements (annual internal reports, pollutant loads from point sources to the marine environment and Pollutant Release and Transfer Register reporting (Section 3))

## **2. OVERVIEW OF THE MAIN FEATURES OF THE WASTEWATER AND SLUDGE REGULATIONS**

### **2.1 Rationale for Regulations**

The discharge of polluted water and industrial sludge from human activities, the use of fertilisers, pesticides and agrochemicals and over pumping of coastal aquifers pose threats to Jamaica's surface and underground water quality. The quality of surface and underground water in several areas of Jamaica has been severely affected and is threatened in other areas. Water quality standards have been established for drinking, irrigation, industrial and recreational uses and for ambient freshwater and sea water. Measurements of water quality in selected wells, rivers and springs between 1996 and 1999 exceeded the applicable standards for irrigation, industrial use, recreation and ambient water quality standards. Ambient and recreational water quality standards were exceeded in all river basins except for the Martha Brae basin which met the ambient water quality standards. The discharge of untreated or partially treated sewage, industrial effluent and surface runoff into the sea has also affected near-shore coastal waters especially the Kingston Harbour.

The exceedances of limits for various parameters set out in the national Ambient Water Quality Standards in the various river basins are accounted for by one or more of industrial effluent sources, run-off from land during rain events, saline water intrusion or bacterial contamination. The presence of Coliform bacteria indicates contamination from faecal pollution generated from human or animal excreta. High levels of nitrate found in groundwater in the Kingston basin are caused by contamination generated from soak away pits used for sewage disposal. Some wells in the Rio Cobre, Black River and Martha Brae basins have been abandoned because of pollution from trade effluent released from alumina refining and rum distillery operations. The severe pollution of Kingston Harbour is due in part to discharges of trade effluent and sewage from facilities in the Kingston Metropolitan Region (KMR) and Rio Cobre basin. Trade effluent accounts for between 24% (during high flow) and 44% (low flow) of the organic pollution in Kingston Harbour while sewage contributes between 29% (high flow) and 53% (low flow). The organic pollution is measured by the biochemical oxygen demand (BOD).

Because of the existing damage and threats to water quality in various basins, it is vital that steps are taken to arrest or reverse the pollution

and to remove the threats posed to water quality by human activities. These measures require reduction in the amounts of untreated sewage, trade effluent and industrial sludge that contaminate water basins.

The Regulations address sewage and trade effluent, industrial and sewage sludge, and provide regulatory means to manage wastewater releases from human activities in Jamaica.

## 2.2 Scope of the Regulations

The regulations, *inter alia*:

- ✓ Identify facilities that need to obtain licences;
- ✓ Specify monitoring and reporting obligations;
- ✓ Promulgate various standards (trade effluent, sewage effluent and sludge) that the licensees' effluent or sludge must meet; and
- ✓ Specify sampling and analytical methods that are to be used to monitor effluent and sludge quality.

The Regulations do not apply to discharges of domestic wastewater from:

- A single family residential property treated by on-site treatment systems.
- Residential developments which are to be connected to an approved central treatment system

In addition, the Regulations do not apply to treatment plants that are designed to discharge treated domestic sewage only in amounts less than 1,500 m<sup>3</sup>/yr. Domestic sewage is waste and wastewater from humans or household operations that is discharged to or otherwise enters a treatment works.

The following diagram shows instances in which a licence under the Regulations is not required:

**Figure 2-1 Exemptions under the Natural Resources Conservation (Wastewater and Sludge) Regulations, 2013**

<b>Exemptions under the Natural Resources Conservation (Wastewater and Sludge) Regulations, 2013</b>	
①	No discharge to the environment (closed loop systems). <i>Permit under Permits and Licences Regulations may be required.</i>
②	Exempted under the NRCA Act Section 12 (2)
③	Discharge not from a treatment plant as defined by the Wastewater and Sludge Regulations. <i>Permit and Licence under the Permits and Licences Regulations may be required.</i>
④	Not required if discharge results from domestic wastewater treated by an absorption pit/soak away pit or other prescribed system and is in accordance with provisions prescribed under the Wastewater and Sludge Regulations and any other law pertaining to such disposal.

### **2.2.1 Facilities to be Licensed**

A wide range of pollutants are covered by the Regulations because of their potential to cause adverse effects on water quality, ecology and human health. Water quality can be affected by chemical or biological agents or by virtue of the physical properties of the effluent or sludge. These agents or pollutants can influence the natural and human environment whether directly or indirectly by creating conditions that limit or prevent water use for specific purposes or can cause adverse ecological and human health effects.

The discharge of these pollutants from facilities into surface or underground waters can limit the use of these waters for agricultural, industrial, recreational or potable purposes. Some critical facilities have been identified which require licences under the Regulations. The treatment plants required to obtain a licence have been categorised using the International Standard Industrial Classification of all Economic Activities (ISIC) Code. The costs for applications and their corresponding ISIC and are listed in Table 2-1.<sup>1</sup>

---

<sup>1</sup> All references in the document to ISIC relate to ISIC Rev. 3.1.

Trade effluent, sewage effluent and irrigation water standards have been established for most of the pollutants found in trade effluent and discharges from sewage treatment plants. These pollutants include:

- nutrients (nitrogen [e.g. as nitrate, ammonia] and phosphorus) that can lead to eutrophication of surface and ground waters;
- physical parameters (temperature, colour, conductivity, total suspended solids) that compromise water quality;
- oxygen consuming pollutants [BOD and Chemical Oxygen Demand (COD)]
- organic pollutants that have adverse ecological and human health effects
- heavy metals that are toxic to plant and animal life as well as human health (Zn, Pb, Cd, As, Cr, Cu, Hg, Ni, Se, Ag, Sn)
- biological agents (coliform, Escherichia-coli) that have adverse human health effects
- other pollutants that have adverse effects on human health and well-being if they reach waters that are used for recreation - or for drinking water supply (chloride, sulphate, Na, Be, B, Ca, Ba, CN, Fe, Mn, Mg, colour, pH, detergents).

**Table 2-1 ISIC Codes for activities that are required to obtain a Licence**

<b>ISIC<sup>1</sup></b>	<b>Source of Wastewater Discharge</b>	<b>Fee (J\$)</b>
0502	Aquaculture	50,000
1320	Mining of non-ferrous metal ores (includes bauxite, precious metals)	50,000
1410	Quarrying of stone, sand and clay includes limestone, dolomite, gypsum, clay and industrial sand and gravel	50,000
1422	Extraction of salt	50,000
1542	Manufacture of sugar	65,000
1551	Distilling, rectifying and blending of spirits; ethyl alcohol production from fermented materials	65,000
1553	Manufacture of malt liquors and malt (includes manufacture of beer, stout, ale)	65,000

<b>ISIC<sup>1</sup></b>	<b>Source of Wastewater Discharge</b>	<b>Fee (J\$)</b>
1554	Manufacture of soft drinks; production of mineral waters (includes non-alcoholic beverages, soft drinks, bottled water)	65,000
15xx	Other manufacturing of food products (includes manufacture or processing of fish, meat dairy, grain mill, animal feeds, vegetable and animal oils and fats, bakery products)	65,000
1911	Tanning and dressing of leather	65,000
2320	Manufacture of refined petroleum products	75,000
2411 and 2412	Manufacture of basic chemicals including fertilizers and nitrogen compounds	65,000
242x	Manufacturing of other chemical products (pharmaceuticals, medicinal chemicals and botanical products, paints varnishes and similar coatings, printing ink and mastics, pesticides and other agro-chemical products, soap and detergents, cleaning and polishing preparations, perfumes and toilet preparations)	65,000
2694	Manufacture of cement, lime plaster (includes cement and lime manufacturing)	65,000
2695	Manufacture of articles of concrete, cement and plaster (includes construction articles made of cement, plaster, wood)	65,000
2720	Manufacture of basic precious and non-ferrous metals (includes alumina plants, manufacture of aluminium foil)	75,000
15** and 2***	All other manufacturing	50,000
4010	Electric power generation	65,000
5141	Wholesale of solid, liquid and gaseous fuels and related products	50,000
9000	Sewage	65,000

<sup>1</sup> ISIC Rev. 3.1

### **2.2.2 Discharge of Trade or Sewage Effluent into a Sewage Collection System or Treatment Plant (Regulations 8, 9 and 10)**

Facilities which discharge trade effluent or sewage effluent into a sewage collection system are required to provide the Authority with the written approval of the licensee prior to making the connection to



the sewage collection system. In addition to submitting the written approval, facilities should submit documentation detailing the composition and volume of wastewater generated from the business, industry or manufacturing or trade facility that will be accepted by the licensee. Failure to provide this information constitutes an offence.

Licensees who intend to receive wastewater from a business, industry or manufacturing must obtain written approval from the Authority prior to any agreement to accept such wastewater. The Authority should be informed of any proposed changes to the agreement relating to the composition or volume of the effluent and must give its consent to the amendments or any renewals to the agreement.

## **2.3 Regulatory Agencies**

The NEPA/NRCA has overall responsibility for the implementation of the Regulations, however where appropriate, the NEPA/NRCA will collaborate with the following government agencies:

- Ministry with portfolio responsibility for Health (Environmental Health Unit, Pesticides Control Authority)
- Ministry with portfolio responsibility for Agriculture (Rural Physical Planning Division, National Irrigation Commission and Rural Agricultural Development Authority)
- Water Resources Authority
- National Solid Waste Management Authority
- Jamaica Bauxite Institute

The NRCA/NEPA may consult with any other government agency and department where appropriate.

## **2.4 Structure of the Regulations**

The regulations consist of fifty seven (57) numbered paragraphs with six (6) Schedules.

An outline of each of the numbered paragraphs is as follows:

### ***Part I. Preliminary***

1. Citation.
2. Interpretation.
3. Natural Resources Conservation Authority (Permits and Licences) Regulations, 1996, not to apply.

### ***Part II. Class I and II Waters***

4. Declaration of waters within the Convention Area as *Class I* or *II* waters.

***Part III. Licences***

5. Application for licence to operate a treatment plant.
6. Application for licence to construct sewage wastewater treatment facility.
7. Application for licence for discharge of sewage and trade effluent into the environment.
8. Discharge of trade effluent or sewage effluent into sewage collection system or wastewater treatment plant.
9. Licensee to have Authority approval to receive wastewater from business, etc.
10. Licensee shall inform Authority of changes to agreement.
11. The Authority may consult on applications.
12. Renewal of licences.
13. Modification of licences.
14. Authority may suspend or revoke a licence.
15. Notice to suspend or revoke a licence.

***Part IV. Specifications of a Treatment Plant***

16. Complete set of drawings and plans.
17. Flow-measuring device.

***Part V. Trade Effluent and Sewage Effluent Standards and Measurements***

18. Effluent standards.
19. Authority may review trade effluent or sewage effluent standards.

***Part VI. Operation and Maintenance of Treatment Plants***

20. Operations and maintenance manual
21. Standby power treatment plant during equipment malfunction.
22. Periods of maintenance and upgrades of treatment plant.

***Part VII. Use of Marine Outfalls and Outfall Pipelines***

23. Use of marine outfalls.
24. Use of outfall pipelines.

***Part VIII. Monitoring and Reporting***

25. Monitoring and reporting requirements.

***Part IX. Reuse for Irrigation Purposes***

26. Irrigation of lawns and agricultural applications.

***Part X. Confirmation Testing of Trade Effluent and Sewage Effluent***

27. Confirmation testing of trade effluent and sewage effluent.

***Part XI. Treatment of Septage***

28. Domestic septage and industrial septage.

***Part XII. Management Practices for Sewage and Industrial Sludge***

29. Sewage sludge.

30. Treatment of sewage sludge.
31. Disposal of sewage sludge.
32. Industrial sludge shall not be released into the environment.
33. Application for hazardous sludge.
34. Industrial sludge shall be harmless and suitable for disposal.
35. Prohibition of unauthorized persons, livestock and other animals.
36. Discharge of sewage sludge or industrial sludge.
37. Monitoring, sampling and analysis.
38. Testing of sludge for use in agriculture.

***Part XIII. Control Order***

39. Control order may be issued.

***Part XIV Compliance Plan***

40. The Authority may request a compliance plan.

***Part XV. Actions by the Authority***

41. Authority shall issue a warning notice.
42. Other actions by Authority.
43. Further actions.

***Part XVI. Fees for Effluent Discharges***

44. Annual effluent discharge fee.
45. Discount on discharge fees.

***Part XVII. Pollutant Release and Transfer Register***

46. Pollutant Release and Transfer Register.

***Part XVIII. Requirement to Report Spills and Leaks***

47. Requirement to report spills and leaks.

***Part XIX. Fees***

48. Fees.

***Part XX. Civil Remedies***

49. Recovery of annual discharge fees.

***Part XXI. Transitional***

50. Licences for construction and operation of treatment plants.
51. Unlicensed effluent discharges.
52. Sewage treatment plant to meet new standards.
53. Sewage effluent standards.
54. Discharging of trade effluent from treatment plant.
55. Waiver of discharge fees.
56. Signs.

***Part XXII. General Penalty***

57. General Penalty.

**Schedules**

FIRST SCHEDULE

*Form 1*

**Licence Applications and Notices**

Applications for -

	Licence to Operate Treatment Plant for the Discharge of Trade Effluent or Sewage Effluent;
	Licence to Construct a Treatment Plant;
	Licence to Reconstruct or Alter a Treatment Plant;
	and
	Licence to Discharge Trade Effluent or Sewage Effluent into the Environment
<i>Form 2</i>	Application for Renewal of Licence to Operate Treatment Plant and Discharge Effluent
<i>Form 3</i>	Notice of Intention to Suspend Licence
<i>Form 4</i>	Revocation Notice
SECOND SCHEDULE	<b>Signs</b>
THIRD SCHEDULE	<b>Sewage Effluent, Trade Effluent and Sludge Standards</b>
FOURTH SCHEDULE	<b>Reporting Forms</b>
<i>Form 1</i>	Sewage Effluent Monthly Reporting Form
<i>Form 2</i>	Weekly, Monthly or Quarterly Monitoring Report for Trade Effluent
<i>Form 3</i>	Annual Sewage Effluent Reporting Form
<i>Form 4</i>	Annual Trade Effluent Reporting Form
<i>Form 5</i>	Form to Report Spills and Pollution Incidents
<i>Form 6</i>	Quarterly and Annual Industrial Sludge Reporting Form
FIFTH SCHEDULE	<b>Approved Test Methods for Sewage, Trade Effluent and</b>
	<b>Sludge</b>
SIXTH SCHEDULE	<b>Schedule of Fees</b>
<i>Part A</i>	Application Fees
<i>Part B</i>	Discharge Fees per Tonne for Discharges into the Environment
<i>Part C</i>	Assessable Pollutant for each Licensable Discharge
<i>Part D</i>	Method to Calculate Discharge Fees

## **3. APPLYING FOR LICENCES AND REPORTING ACCORDING TO LICENCE REQUIREMENTS**

### **3.1 Introduction to Environmental Licences**

The Licences issued under the Natural Resources Conservation (Wastewater and Sludge) Regulations, 2013 is a legal instrument that is enforceable. The licence is granted based on information provided in the licence application form, supporting information requested on the form and any additional information submitted by the Licensee. The information includes specifications of the processes, equipment and pollution control devices that are present at the facility.

The licence specifies operational requirements including a monitoring plan, effluent and sludge discharge limits and monitoring and reporting requirements. Where applicable, if trade effluent or sewage effluent standards are exceeded, the licence conditions may include a Compliance Plan (that will specify the requirement for a facility to implement pollution control or other measures to bring the effluent releases into compliance with the standards) or a Nutrient Management Plan (NMP) (for cases where application of sewage effluent, trade effluent and sludge can be demonstrated to reduce the need for fertiliser and cause no environmental harm).

Where a Compliance Plan is required, the licence conditions will include requirements for the licensee to complete physical and biochemical improvements or modifications to the plant and achieve effluent quality according to a specified schedule and with measurable milestones.

### **3.2 Specifications for the Issuing of Licences**

A licence is required if:

- You intend to operate a treatment plant for the discharge of trade or sewage effluent;
- You are constructing a sewage or industrial wastewater facility;
- You intend to reconstruct or alter the treatment works;
- You intend to discharge trade effluent or sewage effluent either directly into the environment or ; and

- You discharge sewage effluent equal to or greater than 1,500 m<sup>3</sup>/year.

### **3.3 Licence Application Process (Regulations 5, 6, 7 and 12)**

Initial Licence applications shall be made no later than twelve (12) months after promulgation of the Regulations.

Licences are valid for a period of five (5) years. Applications for renewal, including payment of the prescribed fee, should be made no later than six (6) months prior to the expiry date of the licence.

All applications must be accompanied by the completed licence application form [Form 1 of the First Schedule of the Natural Resources Conservation (Wastewater and Sludge) Regulations, 2013], the applicable fees, and where applicable a Compliance Plan and any other document requested by the Authority in accordance with the checklist provided by the Agency. Where required, plans and drawings should be stamped/sealed by a registered Professional. In instances where applications are refused the **application fees paid will not be refunded.**

All Licence applications must be submitted to the office of the NEPA at 10 Caledonia Avenue, Kingston 5.

#### **3.3.1 Completing the Licence Application Form (First Schedule)**

##### **General instructions for Applicants**

- Complete the entire application form [Form 1 of the First Schedule of the Natural Resources Conservation (Wastewater and Sludge) Regulations, 2013], except for the shaded areas and ensure that the application is signed (last page of the application) by the Chief Executive Officer (CEO) or Owner of the facility or designate;
- List all attachments and supporting documents;
- Submit proof of payment for application fee (Table 2-1);
- Where information is not applicable the entry must be "N/A";
- The application form [Form 1 of the First Schedule of the Natural Resources Conservation (Wastewater and Sludge) Regulations, 2013] must not be altered in any way. Applications that are not in the same format and sequence will not be accepted by NEPA. If supplemental information is submitted, it should be provided on a separate page and included in the list of attachments;
- Incomplete applications will not be accepted;

- The date of receipt will be the date on which a complete application is received and accepted.

The following instructions in Table 3-1 apply to selected sections of the licence application form [Form 1 of the First Schedule of the Natural Resources Conservation (Wastewater and Sludge) Regulations, 2013] and attachments.

**Table 3-1 Requirements for completing Licence Application Form and preparing attachments**

Item	Requirement
General and non-confidential description of plant activities	Description must be entered which is consistent with the description for the ISIC code(s) entered.
Description of processes at the plant	<p>This section should include a brief narrative description of the general nature of the business and the type of industrial and/or commercial activity at the plant including what specific products are manufactured or produced and/or what services are provided.</p> <p>In contrast to the general description, there must be a detailed description of the processes at the facility which generate wastewater. The description should include information such as any modifications to your process water/storm water handling facilities, the start-up or shutdown of any process or treatment units, any wastewater recycle projects, or any changes in production throughput.</p>
Attachments	The description of the plant process (es) may require attachments such as an emergency response plan (required), compliance plan (if necessary), a monitoring plan (required), sludge management plan (required), nutrient management plan (as required) and pollution prevention programme (optional).
Plant capacity data	Plant capacity data should indicate the <b>maximum</b> production rate at which the facility or plant can operate. This includes the maximum amount of water use as well as products and raw materials when the plant operates at its maximum.
Impoundments	For each impoundment (e.g. lagoons or ponds) used for the treatment, disposal, containment, or evaporation of wastewater, the following must be provided:

Item	Requirement
	<p>Type of liner and the design characteristics of the liner;</p> <p>For impoundments or lagoons or ponds using a synthetic liner: liner permeability, liner thickness, test results on liner compatibility with appropriate wastes, test results from clay borrow source, test results from liner construction, etc; and</p> <p>For impoundments using <i>in-situ</i> soils as the liner: soils boring information, the depth of impermeable clay soils, test results on soil permeability, procedures for compaction of top layer of <i>in-situ</i> soil, etc.</p> <p>Dimensions:</p> <p>The dimensions of the impoundments (e.g. length, width, depth from water surface at capacity, depth from natural ground level, and depth of freeboard). Depth from water surface is the depth from the water surface at the impoundment's maximum capacity excluding the freeboard. Depth below the natural ground level should not include bermed or elevated portions of the impoundments. Indicate the freeboard required for existing permits or licences. Provide all dimension units in metric units (metres and cubic metres or litres); and</p> <p>For impoundments with irregular shapes, surface area (instead of length and width), the average depth, and the maximum depth below natural ground level.</p>
Leak detection system	If there is a leak detection system, a description of the type of leak detection system and a reference (manufacturer's specification) for the detailed description of the system must be provided.
A description of how any sewage/industrial sludge from any treatment process or from any other process or activity at the facility is treated	<p>Include a description of:</p> <ul style="list-style-type: none"> <li>•Each process used to treat or store sewage/industrial sludge at the facility.</li> <li>•The type of liner and the design characteristics of the liner (if liner is used) <ul style="list-style-type: none"> <li>➤ For impoundments or lagoons or ponds using a synthetic liner: liner permeability, liner thickness, test results on liner compatibility with appropriate wastes, test results from clay borrow source, test results from liner construction, etc.</li> </ul> </li> </ul>



Item	Requirement
	<p>➤ For impoundments using <i>in-situ</i> soils as the liner: soils boring information, the depth of impermeable clay soils, test results on soil permeability, procedures for compaction of top layer of <i>in-situ</i> soil, etc.</p> <p>Dimensions:</p> <p>The dimensions of the impoundments (e.g. length, width, depth from water surface at capacity, depth from natural ground level, and depth of freeboard). Depth from water surface is the depth from the water surface at the impoundment's maximum capacity excluding the freeboard. Depth below the natural ground level should not include bermed or elevated portions of the impoundments. Indicate the freeboard required for existing permits or licences. Provide all dimension units in metric units (metres and cubic metres or litres)</p> <p>For impoundments with irregular shapes, submit surface area (instead of length and width), the average depth, and the maximum depth below natural ground level.</p>
<p>A description of each method or process used to dispose of sewage/ industrial sludge</p>	<p>The description must indicate how waste is transported off-site and must include the locations and destination both on-site and off-site of the industrial sludge and a list of all persons who transported industrial sludge off-site and the amounts of industrial sludge that is transported off-site.</p> <p>Note: Red mud tailings ponds should be described in this section. Note that in some cases supernatant is reused but the red mud is not re-circulated and hence such tailings ponds, stacking areas and the like are described here. Disposal sites that are no longer in use and which contain red mud should be included. When such sites are <u>fully and formally</u> rehabilitated they should not be included.</p> <p>Provide information about the owner, location, handling, storage practices, treatment (if necessary) of facility accepting sludge for additional processing,</p>

Item	Requirement
	which should be licensed, and application of by-process and disposal practices or end-use of the sludge after treatment.
Maps and Drawings	<p>Maps should be metric scale 1:1,250 map if the property is located in a city or town or a metric scale 1:12,500 map.</p> <p>Old maps in English units will not be accepted.</p> <p>The 1:1,250 and 1:12,500 scale metric maps can be obtained from:</p> <p>National Land Agency  Surveys and Mapping Division  23 ½ Charles Street  Kingston.  Telephone: 922-6630-5  Facsimile: 967-1010  Email: <a href="mailto:asknla@nla.gov.jm">asknla@nla.gov.jm</a></p>
Map showing plant boundary	<p>The map for the facility must show the following:</p> <p>a) Plant Boundaries</p> <p>The property boundary, the scale of the map and the direction of true north. If the property is located within a city or town, a planimetric city map(s) 1:1,250 scale metric coordinates map may be used.</p> <p>b) The location of all storm water drains, all liquid process streams, all trade effluent discharge points, the locations where sewage/industrial sludge is formed or stored and all sampling points</p> <p>c) The location of each point of discharge of trade/sewage effluent from the property</p> <p>d) The location of each point of discharge of storm water. Make sure the JAD 2001 coordinates and unique ID numbers are assigned to each point.</p> <p>e) The location of each sampling point for trade/sewage effluent discharge. Assign JAD 2001 coordinates and unique ID numbers are to each point. Identify points where there is a control order, Compliance Plan or other licence conditions that require monitoring, on the map.</p> <p>f) The location of each connection to a NWC or other sewer for treatment of domestic (or domestic</p>

Item	Requirement
	<p>combined with industrial) waste. Make sure the JAD 2001 coordinates and unique ID numbers are assigned to each point.</p> <p>g) The boundaries of any trade effluent treatment ponds or other wastewater treatment facilities on the property (e.g., subsurface drain field, storage ponds for storm water, treatment ponds or vessels etc.)</p> <p>h) all ponds including storage/evaporation/holding ponds on the property</p> <p>i) the boundary for each storage or disposal site for industrial sludge</p>

### **3.3.2 Use of Marine Outfalls and Outfall Pipelines (Regulation 23)**

If the use of a marine outfall is requested, the following information should be submitted with the request:

- A model of the plume behaviour of the effluent in the coastal and marine environment;
- The data, studies and calculations that show that the proposed outfall will allow for an effluent quality which is still acceptable and will not affect the marine environment beyond the levels already established for the ambient water quality;
- The data and studies to show the effect of the effluent on the flora and fauna of the marine environment, within the sphere of influence of the plume as described in the first bullet above;
- A drawing of the route of the marine outfall pipe and the construction material and biophysical survey of the route of the pipe, including the method of laying the pipeline on the floor of the sea and stabilization method; and
- Bathymetry of the seafloor along the alignment of the pipeline.

Where outfall pipelines are proposed to be installed for the discharge of sewage effluent on the foreshore and floor of the sea, an application for a licence in accordance with section 5 of the Beach Control Act must be made. Where such a licence is approved the outfall pipelines must be installed in such a manner as not to interfere with the passage of marine vessels.

### 3.4 Discharge of Trade or Sewage Effluent into a Sewage Collection System or Treatment Plant (Regulations 8, 9 and 10)

Treatment plants that intend to discharge trade effluent or sewage effluent into a collection system should provide the Authority with the following information:

- ✓ the name of facility;
- ✓ type of wastewater;
- ✓ characteristics of wastewater to be treated;
- ✓ layout of pre-treatment facility including geo-referenced sampling point (if applicable);
- ✓ treatment plant capacity;
- ✓ technology of treatment plant; and
- ✓ an agreement between the licensee and the party that will be generating the wastewater.

### 3.5 Preparation of Compliance Plans (Regulation 40)

Facilities are required to prepare and submit a Compliance Plan when they are not in compliance with the applicable requirements under the Regulations. It is anticipated that Compliance Plans will be required at the initiation of the licensing system for several existing facilities. A guide for the preparation of the compliance plan is outlined in Table 3-2 below.

**Table 3-2 Preparation of Compliance Plans**

<b>Compliance Plan Item</b>	<b>YES</b>	<b>NO</b>	<b>What should be included</b>
(a) a description of the current compliance status			<p><b>Item A</b></p> <p>Summary of the aspects which are out of compliance.</p> <p>Suggested text is as follows. Substitute the text in square brackets [] with the facility name, pollutants, dates, etc., as is appropriate.</p>

Compliance Plan Item	YES	NO	What should be included
			<p>The [facility name] is not in compliance with the effluent standards for [pollutants/parameters a, b, c] from the [** process(es)/unit] and with the levels of [pollutants x, y, z] in wastewater/trade/sewage effluent and/or sewage /industrial sludge for the period [** 20** to ** 20**].</p> <p>The [facility name] is not in compliance with the [***] reporting requirements as specified in the Wastewater and Sludge Regulations, 2013.</p> <p>The [facility name] is not in compliance with the [**] requirements as specified in the Wastewater and Sludge Regulations, 2013</p> <p>A list of all wastewater effluent and sludge sources</p> <p>Description of the location of all discharge points where pollutants exceed the relevant effluent and sludge standards</p> <p>Description of the monitoring locations of the effluent and sludge</p> <p>List other administrative or other requirements that have not been satisfied.</p> <p>Description of the processes used to treat effluent or sludge</p> <p>A general description of the reasons for exceedance of the relevant standard(s). Include a statement on each of the following, where applicable:</p> <ul style="list-style-type: none"> <li>• Absence of treatment method</li> <li>• Maintenance (lack of )</li> <li>• Frequent process upsets</li> <li>• Inadequate capacity or size of unit operation/process</li> <li>• Inadequate or inappropriate treatment technology</li> <li>• Inadequacy of chemical inventory</li> </ul>

Compliance Plan Item	YES	NO	What should be included
			<ul style="list-style-type: none"> <li>• Power supply</li> <li>• Rainfall events</li> </ul>
(b) a list of the pollutants that exceed the effluent standards			<p><b>Item B</b></p> <p>A table is to be provided with dates of samples, monitoring location(s), measured pollutant concentrations/levels for each sample with one or more pollutants exceeding a standard</p>
(c) methods used to determine the facility's compliance status			<p><b>Item C</b></p> <p>All monitoring, record keeping, reporting procedures [monitoring schedule, monitoring protocol (who does sampling, how sampled [grab, continuous, proportional (time or flow) composite. which laboratory does analysis, laboratory certification, if any, what Quality Assessment/Quality Control (QA/QC) protocols are followed, how many replicate, duplicate and split samples analysed per year, lab QA/QC, Inter-Laboratory studies that the laboratory participates in, number of participating laboratories, exchange frequency, list of analytical methods used, how and where records are maintained).</p>
(d) A statement that the facility will continue to comply with each applicable requirement			<p><b>Item D</b></p> <p>For example,</p> <p>I, _____, CEO/Owner of the _____ facility, commit to achieve compliance with the Wastewater and Trade Effluent Regulations by ****, 2xxx,</p>
(e) For pollutants listed in ii, and for each applicable			<p><b>Item E</b></p> <p>Description of steps that will be taken to achieve compliance.</p> <p>The description must include as many of the following measures and/or all other measures</p>

<b>Compliance Plan Item</b>	<b>YES</b>	<b>NO</b>	<b>What should be included</b>
<p>requirement for which compliance is not currently achieved at the facility, the owner shall provide detailed statement of how the facility will achieve compliance</p>			<p>and associated activities that will be used to achieve compliance such as:</p> <ul style="list-style-type: none"> <li>• Pollution prevention measures (minimization or reduction of waste in waste streams, water management, pre-treatment}</li> <li>• Engineering measures (manufacturing process changes, changes in raw materials, treatment plant process and/or capacity changes,</li> <li>• Maintenance measures</li> <li>• Administrative measures (e.g. reassignment of responsibilities, internal reporting etc.)</li> </ul> <p>A table with a list of all activities, their start and end dates, indicators to determine completion of each activity, indicator(s) to determine progress, monitoring to determine compliance, indicators to show that a report will be submitted to NEPA (and internally if needed)</p> <p>Note: NEPA is required to utilize the ONE WINDOW approach to ensure that collaborating agencies participate in the review phase, where applicable.</p>
(f) proposed compliance schedule			<p><b>Item F</b></p> <p>Diagram showing the schedule of activities outlined in Item E. If the facility is subject to a control order, the proposed schedule of remedial measures shall incorporate the order and shall be at least as stringent as the order.</p>
(g) a schedule for submission of progress reports to the Authority at least once in			<p><b>Item G</b></p> <p>List showing the dates on which <b>progress reports</b> are to be submitted to NEPA, and indicate what will be in each report. This must be consistent with the dates and steps in Item E and/or Item F;</p> <p>Note: A progress report would typically not include monitoring data but would indicate the completion of installation of equipment, suitable</p>

<b>Compliance Plan Item</b>	<b>YES</b>	<b>NO</b>	<b>What should be included</b>
every six months or more frequently if so required by the licence; and			milestones in construction, or reorganisation etc.
(h) a schedule for the submission of compliance reports to the Authority, at least once in every six months or more frequently if so required by the licence, indicating what (if any) progress has been made in relation to the schedule and the milestones .			<p><b>Item H</b></p> <p>Timetable showing the dates on which <b>compliance reports</b> are to be submitted to NEPA, and indicate what will be in each report. This must be consistent with the dates and steps in Item E and/or Item F.</p> <p>A compliance report must include sampling and monitoring data.</p>
(i) performance targets			<p><b>ITEM I</b></p> <p>The period proposed must be as short as is reasonable and must be consistent with the</p>



<b>Compliance Plan Item</b>	<b>YES</b>	<b>NO</b>	<b>What should be included</b>
to be achieved within two years			nature and cost of the remedies required.

Table 3-3 below provides guidance on determining the duration of compliance plans.

**Table 3-3** Suggestions for determining the duration of compliance plans

<b>Nature of requirements</b>	<b>Time Period for completion</b>
Repair	Minor repairs suggest short periods. Bear in mind time to obtain parts and labour.
New construction	Bear in mind the various phases for construction (budgeting cycle, conceptual design, detailed design, construction, commissioning and testing). Consider costs. Request cost information.
New manufacturing processes	Bear in mind the various phases for construction (budgeting cycle, conceptual design, detailed design, construction, commissioning and testing). Consider costs. Request cost information.
Change in raw materials	Consider time to obtain different raw materials.
Disposal of sludge	Consider interim storage as option only when no facility is available (e.g., for hazardous wastes). Consider costs. Request cost information.

Note that if a compliance plan is refused, NEPA is required to specify the reasons and bases for refusal and you will be required to resubmit the Compliance Plan within sixty (60) days of the notification.

### **3.6 Preparation of Nutrient Management Plans (Regulation 26)**

Wastewater effluent contains valuable resources which includes organic matter and nutrients. However, it also can contain concentrations of chemical contaminants, salts and pathogens that are potentially detrimental to soils, plant growth and/or pose a risk to the wider environment or public health.

In an effort to manage the agrochemical loading of the receiving environment, a critical requirement in the licensing arrangements for facilities is the use of effluent and sludge discharges for beneficial use. Reuse of effluent and/or sludge for selected land applications under specific conditions conforms with environmental stewardship principles which is a win-win for the environment and business operations.

The application for the beneficial use of nutrients from the wastewater streams or discharges are subject to the preparation of a NMP which is to be submitted to the NEPA for review and acceptance by the Ministry of Agriculture and Fisheries and the Water Resources Authority.

The end-user of the resource may be either the owner of the facility or a third party.

It should be noted that the NRCA and the NEPA will not accept responsibility for any adverse events that result from these activities and will not be party to any contractual arrangements between the discharger and end-user.

The preparation of the NMPs is the responsibility of the end-user. The plan is required to provide information on the balance between the ferti-irrigation (fertigation) nutrient uptake by the selected plant(s)/crop(s) and residual amount that will be transported to surface and underground water resources that support critical biota.

Transportation of the resource by pipeline or haulage services is to be clearly defined.

In those cases where the treated effluent and/or sludge is approved by the Authority for beneficial purposes, the quantity and quality are to be recorded at each instance. The annual discharge fees payable are associated with the loadings of selected chargeable pollutants (BOD, nitrate, phosphate) present in the wastewater or sludge. Such fees are reimbursable.

Note that the associated fees are based on **actual use** and not on planned use of nutrients and are therefore reimbursed or used to offset other discharge fees.

A NMP must be submitted and approved in order to obtain the reimbursement.

**The main purpose of the plan is to determine the quantity of the needed nutrients that can be provided by wastewater and/or sludge and the amount to be provided by fertilizer(s).**

The steps in making the determination are:

- Maintain an up-to-date soil analysis (pH, Nitrogen, Phosphate, Potassium and Magnesium every (3) to (5) years), depending on the crop(s) of interest. Use the results to adjust inputs of lime nitrogen, phosphate, potash and magnesium nutrients.
- Assess the total nutrient requirement of the crop using a recognised fertiliser recommendation system.
- Assess the nutrient supply from wastewater, sludge (and organic manures).
- Calculate the need for fertiliser nutrients by deducting the contribution from wastewater, sludge and organic manures from the total crop nutrient requirement.
- Spread wastewater, sludge and organic manures and fertilisers as accurately and uniformly as possible. Equipment must be in good working order and recently calibrated.
- Keep clear field records of cropping, organic manure and fertiliser applications. This will aid future decisions on nutrient management and demonstrate the practical outcome of the plan.
- Update the plan at the start of each cropping year

The requirements for preparing a nutrient management plan are outlined in Table 3-4 below.

**Table 3-4 Requirements for preparing nutrient management plans**

<b>NMP Contents</b>	<b>What is required</b>
Sustainability of the activity	Include a statement that indicates the sustainable use of the land in the long term based on the avoidance of the build-up of substances in the soil
General Information	Wastewater, sewage and/or sludge identified for use and documentation provided where end-user is different from owner of the resource;  The availability, quality of the effluent or sludge as well as the presence and concentration of the nutrient(s) of interest, production rate and quantities considered as

<b>NMP Contents</b>	<b>What is required</b>
	<p>well as application rates;</p> <p>During the review, changes in the characteristics of the product, effluent and/or sludge, treatment process , sewage or trade effluent being treated,</p> <p>Transportation of waste containing any hazardous materials requires an Environmental Permit.</p>
Aerial photograph and topographic map	Map must show field(s) that will be fertilised (or area where beneficial use will occur.)
Soil map of the field(s).	The soil map must indicate soil types that will be used to justify nutrient requirements
A current and/or planned crop production sequence or crop rotation.	Documentation of current and/or planned crop production sequence or crop rotation.
Results of soil, plant, water, manure or organic by-product sample analysis.	Soils are typically analysed for pH, P, K, and Mg every three to five years, depending on the crops. Use the results to adjust inputs of lime and phosphate, potash and magnesium nutrients.
Realistic yield potentials for crops in the rotation.	Yield of crop for area that will be fertilised with wastewater and/or sludge
A quantification (listing) of all nutrient sources.	<p>Estimate of all nutrient sources (commercial fertilisers, manure, wastewater and/sludge sources).</p> <p>Include typical annual rainfall amounts and sources of irrigation water.</p>
Recommended nutrient rates, timing, form and method of application including incorporation timing for the time period of the plan.	Indicate how and when each of the nutrient sources will be applied.
Location of designated sensitive areas or resources and the associated nutrient management restriction.	Provide a list and description of any sensitive areas within 1 km of the area(s) that will be fertilised with wastewater. Sensitive areas must include protected areas, conservation areas, coral reefs, rivers or streams where

<b>NMP Contents</b>	<b>What is required</b>
	water quality is compromised and ground water where there are nearby wells used for drinking water. Also include a description of the water table and its depth below surface, how it has been affected by rainfall.
Plan for implementation, operation, maintenance, record keeping, and complete field-by-field nutrient budget for nitrogen, phosphorus, and potassium for the rotation or crop sequence.	Describe the plan for the delivery of wastewater and sludge derived nutrients to fields, as well as delivery of nutrients derived from commercial and other (e.g., manure) fertilisers. The plan must indicate which fields (and crops grown) will be fertilised, when, and how. Include a sample table that will indicate how records will be kept. The table must include at least all of the elements in the annual reporting for nutrients (Form 6 of the Fourth Schedule)
A statement that the plan was developed based on current standards and that changes in any of these requirements may necessitate a revision of the plan.	Include a statement such as the following.  This NMP was developed based on practices used in the production of [crop x] and took into consideration the soil types present on the [name of farm/field where applied] and other agronomic factors. We will continue to monitor the nutrient requirements and make adjustments to the plan as may be needed.
Signatures	The plan must be signed by the following persons:  Person who prepared the plan CEO of the facility supplying the wastewater and/or sludge <b>and/or</b>  Owner of the field or farm where nutrients will be applied.

### **3.7 Preparation of Wastewater Treatment Plants Operations and Maintenance Manual (Regulation 20)**

The Regulations require owners of wastewater treatment plants to prepare and maintain an Operations and Maintenance Manual that

must include information specified in this regulation. These requirements and how to comply with them are summarised in Table 3-5 below.

**Table 3-5 Requirements for Preparation of Operations and Maintenance Manuals**

<b>Item</b>	<b>Requirements (will vary depending on the complexity of the plant).</b>
(a) a description of the plant	<p>Submit plan-view diagrams of the plant and outfalls, influent sewer manholes, pump stations, force mains, and any piped diversions, overflow dams, or bypass weirs.</p> <p>Provide complete design data in tabular form. The design data may normally be photocopied directly from the approved plans, which must include a complete listing as a reference.</p> <p>Provide a description of how plant is served with utilities and other auxiliary equipment.</p> <p>Describe the standby power system in detail including explicit procedures to be followed on loss of utility power and conversion to standby power, and vice-versa. Provide a complete list of all non-maintained contacts that will have to be manually re-set on each occurrence. Describe the phasing of any start-ups controlled by time-delay relays. Provide instructions on which equipment to re-set and start up first. List of equipment items that may be considered non-critical, description of which start-ups must be staggered, and provide associated instructions.</p> <p>Provide drawing(s) showing the locations of utilities (power drops, main breakers, gas meters, land line telephones / communication equipment, backflow preventers, fuel tanks, chemical storage, and other such auxiliary equipment as may concern firemen responding to an</p>

<b>Item</b>	<b>Requirements (will vary depending on the complexity of the plant).</b>
	<p>alarm.</p> <p>Provide a drawing /map showing the locations of isolation valves, access points and other pertinent features.</p>
(b) a description of the operating procedures, including details of the process operations	<p>Describe each unit process and equipment item in detail. Instructions for start-up, shutdown, operation under various conditions, and control. Provide a troubleshooting guide or manufacturer's guide for each electrical and mechanical feature of the plant.</p> <p>Provide a list of all control and alarm set points and elevations as per schedules in the plans or specifications. Provide sample forms for recording start-up conditions (developed by the engineer or adapted from the manufacturer's standard forms).</p> <p>Describe the operation and control of other mechanical systems such as alarms, telemetry, emergency power and fuel transfer systems, landscaping irrigation, chemical feeders, heating, HVAC (heating, ventilation and air-conditioning), seal water, level controls, flow meters, samplers etc. Describe how these systems work, and their operation and maintenance requirements - including diagrams as necessary.</p>
(c) a list of equipment, including specifications of the equipment	See item a.
(d) maintenance requirements and procedures for the equipment and plant components	Provide lists of periodic maintenance requirements, record-keeping forms, equipment suppliers and service representatives' telephone numbers.
(e) a schedule of maintenance activities to be carried out by operations staff	See item b.
(f) an effluent monitoring schedule	<p>Provide:</p> <ul style="list-style-type: none"> <li>• a schedule indicating when and where samples must be taken</li> <li>• a map showing outfalls and all</li> </ul>

<b>Item</b>	<b>Requirements (will vary depending on the complexity of the plant).</b>
	<p>sampling locations</p> <ul style="list-style-type: none"> <li>• summary information on sampling protocols</li> <li>• one complete set of all worksheets/reporting forms including period (monthly) and annual</li> </ul> <p><b>Sludge Disposal and Analysis</b>  Reference the information necessary for the operator to ensure safe and proper handling and disposal of sludge. Summary of the approved Sludge Management Plan and provision for sludge disposal records.  Provide descriptions of the operation, maintenance, and control of sludge storage and disposal equipment, tanks, ponds, spreaders, sprayers, and so on. Provide one copy of sludge disposal log forms.  Provide a list of approved sites for disposal or use, contacts, map for such sites, copies of contracts and approvals for transport and disposal if applicable.</p> <p><b>Effluent Reuse</b>  If applicable, provide a copy of the NMP or Irrigation Reuse Plan including information the WWTP operator may require in complying with this plan.</p>
(g) an emergency management plan which shall include but is not limited to risks associated with spills, floods, hurricanes or fires.	<p><b>Safety Requirements.</b>  The Emergency Management Plan manual must make reference to occupational hazards and safe practices. There must also be a separate section in the manual on safety. The safety section must include information on specific hazards at the plant, and must refer to the safety training program and standard safety procedures handbook.</p> <p><b>Emergencies.</b>  A separate section providing a listing of emergency telephone numbers, including the NEPA and Environmental Health Unit</p>



Item	Requirements (will vary depending on the complexity of the plant).
	(EHU) staff/office to be called to report any sewage overflow or other problem. Describe or reference procedures for chlorine leaks and neighbourhood evacuation, fires, power and phone outages, and so on.
(h) any other information relevant to the good operation of the plant;	See item b

### 3.8 Preparation of Monitoring Reports (Regulation 25)

The Regulations require reporting of monitoring data as well as pollution incidents by all licensed facilities. Monitoring data must be reported throughout the calendar year at the frequency specified in the licence, and monitoring and load data must be reported annually by all facilities.

The Fourth Schedule contains the forms for filing periodic reports (daily, weekly, monthly, quarterly or annual as the case may be) and to report spills and pollution incidents.

The annual reports for trade and sewage effluent are the bases for calculating the discharge fees that are payable.

**In all reports, the tables with reported values must be copied and repeated for each discharge point**

The annual report for trade effluent (Form 4, Fourth Schedule) must accompany the initial licence application or renewal (First Schedule). Except for the initial (very first) application, the annual report for trade effluent must be accompanied by the discharge fees for the releases made in the previous calendar year.

FOURTH SCHEDULE (Regulations 17 and 25)

- Form 1 Sewage Effluent Monthly Reporting Form
- Form 2 Weekly, Monthly or Quarterly Monitoring Report for Trade Effluent
- Form 3 Annual Sewage Effluent Reporting Form
- Form 4 Annual Trade Effluent Reporting Form
- Form 5 Form to Report Spills and Pollution Incidents

### 3.8.1 Preparation of Periodic Reports (daily, weekly, monthly or quarterly) For Sewage Treatment Plants

A report must be submitted for each discharge point in accordance with the information below in Table 3-6.

**Table 3-6 Requirements for preparing Periodic Reports for Sewage Treatment Plants**

<b>Monthly Report Fourth Schedule – Form 1</b>	
<b>Item</b>	<b>Requirements</b>
Date	Enter the date on which you submit the report
Reporting Period	Indicate the period ( <i>month</i> ) for which data are provided. Note: Be sure to provide a continuous (i.e., without any gaps in dates) period for the entire year.
Name of Plant	Indicate the name of the plant (same as in Licence)
Location of Plant	Indicate the address of the plant
NRCA Permit No	Indicate the permit number for the plant (if one was issued)
NRCA Licence No.:	Indicate the Licence number (under these Regulations or the Natural Resources Conservation (Permits & Licences) Regulations, 1996 if applicable)
Signature	Ensure that the report is signed.
<b>The table with the reported values must be copied and a table submitted for each discharge point.</b>	
Data	<p>Make sure that all of the required data as specified in the licence (frequency of measurement, number of sampling locations, parameters [including septage and sludge], method used, etc.) are reported. Include also, the calibration data for each parameter, the date and time of each sample and the associated results for that date and time.</p> <p>The flow reported must be the average flow for the week Be sure to use the proper units especially for nitrate and phosphate.</p>
Test Methods used	Include the name of test methods used.
Regulatory	List the dates and numbers of any inspection

<b>Monthly Report Fourth Schedule – Form 1</b>	
<b>Item</b>	<b>Requirements</b>
Inspections/Visits	visits by NEPA and EHU staff
<b>OPERATION AND MAINTENANCE</b>	
Average daily flow per month	Provide the average daily flow per month for influent and effluent.
Peak daily influent flow	Provide the peak (highest) daily influent flow for the month
Septage received	Indicate the quantity (volume in m <sup>3</sup> ) of septage received at the plant.
Sludge removed	Indicate the quantity (volume in m <sup>3</sup> ) of sludge removed from the plant.
Equipment failures	List the dates and nature of all equipment failures and process problems, including periods of power outages, plant upsets, mechanical breakdowns etc.
Process problems	It may be difficult to separate process problems from equipment issues.
Maintenance	Indicate whether a maintenance inspection has been carried out and the date if applicable.
Repairs, rehabilitation or upgrades	Describe the activities, including the start and end dates.
Additional Sewage received	Indicate if any additional inflows have been received. These would include new connections to the sewerage system.
Changes in Staffing	Indicate any changes in staffing (plant operators, management)
Comments:	Violation of standards  It is recommended that you provide a list of all violations of standards and indicate what follow up action you propose. If a Compliance Plan is in operation note that fact.
The monthly report form should be used for preparing reports for all sampling intervals required by the Authority up to one month. Collated monthly reports are to be submitted to the agency based on the frequency at which the Authority requires the submission of these reports for e.g. quarterly, twice yearly.	

### **3.8.2 Preparation and Submission of Monitoring (Weekly, Monthly, Quarterly) Reports for Trade Effluent (Fourth Schedule: Form 2)**

**A report must be submitted for each discharge point**

The requirements for completing period reports for each trade effluent monitoring point are summarised in the Tables 3-7, 3-8 and 3-9.

**Table 3-7 Requirements for the Monitoring Reports for Trade Effluent**

<b>Item</b>	<b>Requirement</b>
Date	Enter the date on which the report is prepared.
Reporting period	Indicate the period (e.g., month or quarter) for which the data are being provided  Note: Be sure to provide a continuous (i.e., without any gaps in dates) period for the entire year.
Plant Name	The name of the facility (same as that stated in the issued Licence)
Location of Plant	Indicate the street address of the plant
Permit and Licence	Indicate accurately the Permit number and or Licence number (under these Regulations or the NRCA (Permit and Licence) Regulations 1996 if applicable)
Plant ID	This is the identification of the treatment plant as stated in the licence

**The table with the reported values must be copied and a separate table submitted for each discharge point.**

**Table 3-8 Requirements for reporting on parameters specified in licence**

<b>Be sure to include ALL of the parameters specified and required in the issued licence</b>		<b>Parameter values for each sample</b> Add more columns if needed Be sure to use the same units for each parameter analyzed in all sample
<b>PARAMETER</b>	<b>Units</b>	<b>Requirements for each sample (column of Sample Values)</b>
Sample Date	yyyy/mm/dd	Note the date format

<b>Be sure to include ALL of the parameters specified and required in the issued licence</b>		<b>Parameter values for each sample</b> Add more columns if needed Be sure to use the same units for each parameter analyzed in all sample
<b>PARAMETER</b>	<b>Units</b>	<b>Requirements for each sample (column of Sample Values)</b>
Analysis Date	yyyy/mm/dd	Obtained from Site (Field) and/or Reports
Sampling Location		Determined at the site of the treatment plant in accordance with the licence conditions
JAD 2001 Coordinates of Sampling Location		Coordinates compatible with regulatory requirements
<b>Sample ID</b>		Specifically assigned for repeatability
Flow	m <sup>3</sup> /h	Flow must be reported for each sample. If a flow is missing, there are procedures for filling in missing values. Fill in missing flow values as indicated in Table 4.2, Section 4.
Biological oxygen demand (BOD <sub>5</sub> )	mg/L	
Chemical Oxygen Demand (COD)	mg/L	
Faecal Coliform	MPN/100 ml	
Nitrate as NO <sub>3</sub>	mg/L	Note that the parameter is expressed as NO <sub>3</sub>
Oil & grease	mg/L	
pH		Measured in situ
Caustic soda (as NaOH)#	mg/L	
Phosphate as PO <sub>4</sub>	mg/L	Note that the parameter is expressed as PO <sub>4</sub>
Temperature	°C	Measured at the site
Total Coliform	MPN/100 ml.	
Total Dissolved Solids (TDS)	mg/L	
Total Suspended Solids (TSS) (maximum monthly average)	mg/L	
Total suspended solids (TSS) (maximum daily average)	mg/L	
Ammonia/ammonium	mg/L	

Be sure to include ALL of the parameters specified and required in the issued licence		Parameter values for each sample Add more columns if needed Be sure to use the same units for each parameter analyzed in all sample
PARAMETER	Units	Requirements for each sample (column of Sample Values)
measured as NH <sub>4</sub>		
Barium	mg/L	
Beryllium	mg/L	
Boron	mg/L	
Calcium	mg/L	
Chloride	mg/L	
Colour	mg/L	
Cyanide (free)	mg/L	
Cyanide (Total as CN)	mg/L	
Detergent	mg/L	
Dissolved Oxygen (DO)	mg/L	
Fluoride	mg/L	
Iron	mg/L	
Magnesium	mg/L	
Manganese	mg/L	
Phenols	mg/L	
Sodium	mg/L	
Sulphate	mg/L	
Sulphide	mg/L	
Temperature	°C	
Total Organic Carbon (TOC)	mg/L	
Trace Metals:		
Arsenic	mg/L	
Cadmium	mg/L	
Chromium	mg/L	
Copper	mg/L	
Lead	mg/L	
Mercury	mg/L	
Nickel	mg/L	
Selenium	mg/L	
Silver	mg/L	
Tin	mg/L	
Zinc	mg/L	
Total Heavy Metals:	mg/L	

**Table 3-9 Requirements for Sampling and Testing**

<b>Item</b>	<b>Requirements</b>
Test Methods used	Provide a list of all test methods used.
Sampling methods	Indicate the type(s) of samples (grab, proportional) and the reference to the document that describes the method.
Name of laboratory	List the name of the laboratory or laboratories that performed the analyses.
Location of documentation	Provide a reference that indicates the location within your facility of the paper or electronic copies with calibration and quality control each set of samples.
Other	Indicate whether or not a Compliance Plan or Control Order is in force.
Equipment or process failures	List the dates and nature of all equipment failures and process problems. Including periods of power outages, plant upsets, mechanical breakdowns etc.
Repairs, rehabilitation, upgrades	Indicate and list any repairs or upgrades made to equipment that would affect effluent and/or sludge quality or volume.
Comments	Violation of standards  It is recommended that you provide a list of all violations of standards and indicate what follow up action you propose. If a Compliance Plan is in operation note that fact.

**3.8.3 Preparation of Annual Sewage Effluent Reporting Form, (Fourth Schedule Form 3)**

**A report must be submitted for each discharge point bearing the information in tables 3-10 and 3-11 below:**

**Table 3-10 Requirements for the Preparation of Annual Sewage Effluent Reporting Form**

<b>Item</b>	<b>Requirement</b>
Date:	Enter the date the report was submitted to NEPA (yyyy/mm/dd)

<b>Item</b>	<b>Requirement</b>
Reporting Year	The reporting year is a calendar year
Name of Plant	The name must be the same as it appears in the licence
Location of Plant:	Enter the address of the plant
NRCA Permit No.	Indicate the permit number (under these regulations or the Permits and Licences Regulations if applicable)
NRCA Licence No.	Indicate the licence number (under these regulations or the Permits and Licences Regulations if applicable)
Capacity of the Plant	State capacity in m <sup>3</sup> /day

The table with the reported values must be copied and a table submitted for each point.

**Table 3-11 Requirements for the Preparation of Annual Sewage Effluent Reporting Form**

<b>Item</b>	<b>Requirement</b>
Monthly data	The average monthly flows and concentrations must have been calculated from the monthly reports. Enter the monthly averages as indicated.
	Include data for any additional parameters that you are required to monitor as specified in the licence.
Annual Load	The annual load is calculated from the sum of each monthly effluent flow times the monthly average concentration.
Annual Exceedances	Sum the numbers of exceedances of standards for all parameters as indicated on monthly reports to provide the total for the calendar year.
Discharge Fees	Indicate the fee for each pollutant and the total.
Regulatory Inspections/Visits	Indicate the numbers of visits by EHU and NEPA staff for the year (get from monthly reports).
Receiving water body	Provide name and location of nearest water body to the discharge point
Septage	Indicate the total amount of septage received for the year. Get from monthly reports.
Sludge	Indicate the total amount of sludge transferred off site for the year. Get from monthly reports.
Sludge on hand	Indicate the amount of sludge on site at the end of the year (December 31).
Repairs, rehabilitation or upgrades	List major repairs and upgrades at the plant (those lasting more than 1 month) indicating the start and end dates. If you have a Compliance Plan that is in force you must include all items that are included in the Compliance Plan.
Biomass harvested	State the amount of biomass harvested for the year.



<b>Item</b>	<b>Requirement</b>
Method of disposal of biomass	Specify in details the method of disposal of the biomass
Additional Sewage Inflows	Account for changes in inflows based on new connections to sewer system coming on stream. Ensure that necessary permits were obtained and that design flow is not exceeded.
Changes in Staffing	Summarise staff changes (net changes during the year).
Comments	These would include public meetings with community groups, newsletters published to describe the facility, tours of facility by groups (more than 6 persons), sponsorship of community activities.
Copies of laboratory reports	Append laboratory reports.
Signature	The report must be signed by the owner or CEO or owner of the facility.

### **3.8.4 Preparation of Annual Trade Effluent Reporting Form (Fourth Schedule: Form 4)**

Instructions for completing these forms are included in Tables 3-12 and 3-13 below:

Note that the table for reporting monitoring data must be repeated for each discharge point.

**Table 3-12 Requirements for the Preparation of the Annual Trade Effluent Reporting Form**

<b>Item</b>	<b>Requirement</b>
Date	Enter the date the report was submitted to NEPA. Ensure the date is in the correct format (yyyy/mm/dd)
Reporting year	The reporting year must be for the previous calendar year in the date above
Name of Plant:	The plant name must be the same as in the Licence.
Location of Plant	Enter the full address (street name, second address line, City/Town/Municipality and Parish
NRCA Permit No.	If a permit was issued for the facility, enter the permit number
NRCA Licence No.	Enter the licence number
Technology used	State the system of treatment applied and type of plant
Amount of biomass harvested	State the total amount harvested over the entire period

Item	Requirement
Estimate of average flow rate of trade effluent	If a monthly or period flow rate is not available, Table 5-2 refers.
Average annual flow rate of trade effluent	Indicate the total trade effluent flow for the year.
Monthly flow rate	Indicate the monthly flow rate in litres. If you were required to sample less frequently (e.g., quarterly), divide the total flow for the period by the number of months in the period and use the result for each of the corresponding months in the period.
Number of reportable incidents	Indicate the number of incidents that were reported for the year
Comments	<p>Community activities must include the following:</p> <ul style="list-style-type: none"> <li>• Public meetings with community groups (specify number of meetings and dates)</li> <li>• Newsletters published to describe the facility (specify number of meetings and dates)</li> <li>• Tours of facility by groups (of more than 6 persons), (specify number and dates)</li> <li>• Consultations including the methods used (surveys, focus groups, community panels, etc.) and number of consultations</li> <li>• Complaint (about environmental issues) handling procedure in place, number of complaints, number resolved</li> <li>• Environmental awareness or education programme</li> <li>• Donations/grants to local communities for environmental issues</li> <li>• Sponsorship of local and national environmental community activities/programmes</li> <li>• Other (specify)</li> </ul>
Plant Operator	The facility's Environmental Manager or operator to sign
Date	Indicate the date when you signed the report
Owner's Signature	Owner or CEO to sign
Date	Indicate the date when you signed the report

**For each parameter that you were required to measure as stated in your licence the information in Table 3-13 is required (copies of laboratory to be attached).**

**Table 3-13 Requirements for reporting on parameters measured in accordance with licence conditions**

Item	Requirement
Number of samples	Enter the total number of samples analysed for the year
Number of samples > standard	Indicate the number of samples that were above the standard
Annual loading	The annual load must be calculated from the sum of each loading ( $\sum C_i \times Q_i$ ) where $C_i$ is the concentration for each sample, $Q_i$ is the flow for the sampling period that the sample represents). Section 6 of this document provides details on how to calculate the load.
Discharge Fee	Indicate the amount of discharge fees enclosed.
Net discharge fees	The net fees payable is the total fees less the incentive amount derived using the information in the Sixth Schedule of the Regulations.

### 3.8.5 Form to Report Spills and Pollution Incidents (Fourth Schedule: Form 5)

The Form to report Spills and Pollution Incidents should be completed in accordance with the requirements set out in Table 3-14 below.

**Table 3-14 Requirements for the Form to Report Spills and Pollution Incidents**

Item	Requirement
Location where spill or incident occurred	Indicate location on property and indicate areas off-site (e.g., receiving water bodies) that are affected or can be affected by the spill
Name and phone number of person who reported the spill and location where they can be contacted	Typically this would be the Environmental Officer or the person who is authorised to file the report.
Date and time of spill	Note the spill report must be completed as soon as possible after the spill land <b>no later than twenty four (24) hours after the spill occurred.</b>
Material(s) spilled	Describe the chemical name (avoid trade names). <i>If a Trade name is provided, be sure that you have the Material Data Safety</i>

<b>Item</b>	<b>Requirement</b>
	<i>Sheets (MSDS) and attach it to the report.</i>
Characteristics of material spilled	Chemical properties that pose danger to the environment or human health. Information such as provided on MSDS must be used.
Amount of material spilled (volume in litres or weight in kg)	Provide an estimate if the exact quantity is not known. Report in metric units (kg or m <sup>3</sup> , litres)
Duration of spill event	Period of time over which the spill occurred
Work completed and/or still in progress in the mitigation of the spill	Describe what work has been and will be completed to contain and clean up the spill and to treat any contaminated material.
Preventative actions being taken to ensure the situation does not occur again	Indicate what actions have been taken so far.
Signature	Person completing the form is to sign.

Copies of laboratory reports are to be attached or included with each monitoring report.

### **3.8.6 Preparation of Quarterly and Annual Industrial Sludge Reporting Form (Schedule Four: Form 6)**

This report is designed to be updated quarterly (Appendix 5). The last quarterly report will also be the annual report where the totals for the year are reported.

The quarterly reports are due at the end of the month following the last month in each of the first three quarters and the fourth quarter's report is due on the last day of February and should conform with the requirements set out in Table 3-15 below.

**Table 3-15 Requirements for the Preparation of the Quarterly and Annual Industrial Sludge Reporting Form**

<b>Item</b>	<b>Requirement</b>
-------------	--------------------

Item	Requirement
1. Date	Ensure the date is in the correct format (yyyy/mm/dd)
2. Reporting year	The reporting year must be for the previous calendar year in the date (item 1).
4. Name, location and permit and licence numbers for the facility	Make sure the information provided here is consistent with that in Schedule 1 (Application form)
5. Quarterly and Annual Release of Industrial Sludge	The report is designed to be updated each quarter. For each type of sludge, one entry per quarter is required.
Period	The quarter is the calendar quarter (Q1 is January, February and March, Q2 is April, May, June, Q3 is July, August, September and Q4 is October, November, December)
Type of sludge	<p>A report for each type of sludge is required. They must be described in item 6 and each type is designated by a letter starting with the letter "A". For each type of sludge use the next letter in the alphabet.</p> <p>(Include description of types A, B, C etc.)</p>
Amount of sludge generated in period (tonne)	<p>This is the total amount of sludge generated at the facility during the quarter</p> <p>In the case of red mud, since supernatant is re-circulated, report two types: net amount of supernatant liquid and amount of red mud solids.</p> <p>Note that spills of supernatant liquid to the environment must be reported as a trade effluent.</p> <p><u>Red Mud Ponds and Similar Structures</u></p> <p>Provide (and justify) the solids content of the red mud that remains in the storage pond <b>and</b> the amount of supernatant including any suspended solids that will/can be re-circulated to the plant. Report these amounts for the end of each quarter.</p>

Item	Requirement
	<p>If you have more than one red mud pond (including those that are no longer in use) prepare a separate table for each pond.</p> <p><u>Dry Stacking Facilities</u></p> <p>For dry stacking disposal sites, report the amount in the dry stacking area assuming nominal moisture content when dry and a separate amount for the supernatant in the in the holding pond. Use the same moisture content for the entire year. Update the value for the moisture content if needed in the last quarter AND revise all data for the entire year.</p> <p>If you have more than one dry stacking site, (including those that are no longer in use) prepare a separate table for each area.</p>
Stored on Site at end of period (tonne)	This is the amount that is stored on site at the end of the period.
Transferred off-site during period (tonne)	This is the amount that is transferred off site during the period.
Other (specify)	Add comments here. Indicate if the transfers were for further treatment or for disposal. Details are provided in the following table in the report.
<b>7. Transfers of sludge off site</b>	
Period	As indicated in previous period above
Type of Sludge	As indicated in previous period above
Date transfer	Indicate each of the dates on which transfers off site took place
Amount transferred	Indicate the total amount of waste transferred off site

<b>Item</b>	<b>Requirement</b>
Recipient	Indicate the <b>name</b> of the facility (waste management site, company that will use, further treat or destroy the sludge) that received the sludge
Address of Recipient (Destination) of Sludge	Indicate the full address (street number and name, additional address if needed, City/Town/Municipality and parish) of the facility that received the sludge
Regulatory inspections/Visits	List the dates and numbers of any inspection visits by NEPA and EHU staff
Equipment or process failures	List the dates and nature of all equipment failures and process problems. Including periods of power outages, plant upsets, mechanical breakdowns etc.
Signatures	The report must be signed by the Chief Executive Officer or owner of the facility. Lab reports must be signed by the facility's environmental laboratory manager or by the laboratory that performed the analyses.
Date	The date on which the report was signed.

The annual amounts of sludge generated, stored on-site and transferred off-site are required for PRTR reporting.

### **3.9 Pollutant Release and Transfer Register (PRTR) Facility Reporting (Regulation 46)**

Facilities licensed by the Authority to release air pollutants, sewage and trade effluent into the air, water and onto land and/or transfer of any waste streams for transfer off-site for disposal and/or treatment including recycling and reuse locally or for export are required to provide such information to the NEPA.

Annual PRTR Reports provide the total quantities of the parameters such as carbon monoxide, sulphur dioxide, nitrogen dioxide, volatile organic compounds, total suspended particulates or fine particulates, toxic or priority air pollutant releases into the air, water and/pr land, wastewater releases such as biochemical oxygen demand, chemical

oxygen demand, pH, nitrates, phosphates, bio-accumulative or heavy metals for each facility.

The PRTR is intended to guarantee public access to information on releases and transfers of certain pollutants and contributes transparency and public participation in environmental decision-making.

The templates for PRTR reporting can be found in the appendices.



## 4. SLUDGE MANAGEMENT

### 4.1 Beneficial Use of Sludge

For the purposes of these Guidelines, beneficial use of sludge will be taken to mean: application for agricultural use, back-fill material for mined-out pits or soil amelioration. Other uses which may be considered beneficial will be assessed by the Authority on a case by case basis to determine whether or not consideration ought to be given regarding the conformity of the requested use to beneficial use as well as the extent to which discounts are to be applied to the applicable discharge fees. Where the application rate of sludge exceeds the nutrient requirement for organic matter, the application will not be considered beneficial use.

Prior to application, sewage or industrial sludge must be stabilized. Stabilization is a chemical or biological process that stops the natural fermentation of the sludge. Stabilizing the sludge results in reduced pathogens, vector attraction and offensive odours. Sewage or industrial sludge destined for reuse must meet the standards set out in Table 5 of the Third Schedule of the Regulations (this has been included as Table 4-1 below).

**Table 4-1 National Treated Sewage Sludge Standards for Fully Treated Sewage Sludge that can be applied to Agricultural Land**

<b>Pollutant</b>	<b>Maximum Concentration #</b>	<b>Annual Pollutant Loading Rates</b>	<b>Jamaican Cumulative loading rates %</b>
	mg/kg (dry weight) basis		kg/ha
Arsenic	65		
Cadmium	75		
Copper	230		

<b>Pollutant</b>	<b>Maximum Concentration #</b>	<b>Annual Pollutant Loading Rates</b>	<b>Jamaican Cumulative loading rates %</b>
Lead	90		
Mercury	0.045		
Molybdenum	09		
Nickel	180 <sup>##</sup>		
Selenium	14 <sup>##</sup>		
Zinc	400		
Cr	830		165
Pathogens	<1,000 MPN/g of total solids (oven dried mass where <i>Viable Helminth Ova</i> <1 per 4g of Total Solids (Dry Weight) <i>Salmonella</i> <3 MPN/4g <i>Faecal Coliform</i> <1,000 MPN/g		

# Based on the 95<sup>th</sup> percentile (rounded to 5mg/kg) of the level of occurrence in Jamaican soils except as noted

## Based on US EPA limits

% Based on 4,400 kg dry weight compost per ha for 45 years

All personnel involved in the management of sludge including, generators, transporters, spreaders and farmers should ensure that the application of the material on land is carried out in an environmentally friendly manner with beneficial effects for agriculture.

Sewage or industrial sludge should not be applied:

- to slopes in excess of 10 % (6 degrees)
- during rainfall
- waterlogged soil

- slowly permeable soils
- highly permeable soils
- land where depth to bedrock is less than 60 cm
- within 50 m of surface waters (on flat land)
- within 100 m of surface waters (downslope)
- within 5 m of surface waters (upslope)
- contaminated sites
- to land if it is likely to adversely affect a threatened or endangered species

Due consideration should be given to the location of sludge application and storage sites to ensure that the transportation, storage and application of sludge does not cause a public nuisance.

The suitability of the land for the application of sewage or industrial sludge and the crops for the sludge can be applied should be determined in consultation with the Ministry of Agriculture and the National Environment and Planning Agency. Maximum application rates as determined in an approved nutrient plan should not be exceeded.

On application sites, sludge should be stored in a dedicated area bunded with compacted earth giving due consideration to drainage and runoff. Storage periods should not exceed 30 days. Drainage from the stockpile area should not be discharged into surface waters. Stockpile areas should be located on maximum slope of 4%. Stockpiling should be of limited duration to reduce vector attraction.

Records should be kept of the quantities of sludge generated, stored, transferred, the dates of transfer, the types of sludge, the recipient and the address of the recipient (as may be required) to facilitate the preparation of the quarterly and annual reports that should be submitted to the Agency.

## **4.2 Management at Waste Water Treatment Plant Sites**

Long-term stockpiling of sludge at WWTP sites is not an appropriate disposal method. Where sludge may cause nuisance odours or have the potential to attract vectors, it should be covered or incorporated into the soil. Stockpile areas should be designed with adequate drainage controls and the provision for an impervious base. Drainage should be managed to prevent the pollution of waters.

## **4.3 Disposal to Landfill**

Sludge that will be disposed of at a landfill must be treated to meet the standards in Tables 6 and 7 of the Third Schedule of the Regulations.

**Table 4-2 Standards for Soil Waste/Industrial Sludge Suitable for Landfill**

<b>Leachate test results not to exceed 100 mg/l</b>	
Parameter	
Ammonia sulphide	Maleic anhydride
Benzidine	Methylamine
Benzyl chloride	Potassium permanganate
Diethylamine	Quinoline
Ethylamine	Strychnine
Ethylenediamine	Tetrachloroethanes

**Table 4-3 Standards for Soil Waste/Industrial Sludge Suitable for Landfill (based on Leachate quality test results)**

<b>Parameter</b>	<b>Concentration (mg/L)</b>
Arsenic	2.5
Barium	100
Cadmium	0.5
Carbon Tetrachloride	0.5
Chromium	5
Cyanide (free)	20
DDT	3
Endrin	0.02
Heptachlor +Heptachlor epoxide	0.3
Lead	5

<b>Parameter</b>	<b>Concentration (mg/L)</b>
Lindane	0.4
Mercury	0.1
Methoxychlor	10
Methyl ethyl ketone	200
Metolachlor	5
PCBs	50
Selenium	1
Silver	5
Etrachloroethylene	3.0
Toxaphene	0.5
Trihalomethanes	10
2,4,5-TP (Silvex)	1
Zinc	500

## **4.4 Transportation**

Transportation of sludge should not result in spillage, odours, or contamination of the sludge being transported. Loads should be covered and dust control procedures implemented to prevent the loss of fine material. No drainage should escape from the vehicle while in transit, if the sludge is not dry. Vehicles should be cleaned in a location where wash down water is prevented from entering the storm water system or surface waters.

Vehicles transporting sludge should carry a manifest stating the vehicle registration number, time, date and location where the sludge was collected and the amount loaded as well as the time, date and location where the sludge is offloaded and the amount offloaded. The signatures of the operator of the facility from which the sludge is collected, the driver and the relevant personnel from the recipient location must be affixed to the manifest. The recipient information must be repeated if the sludge being transported will be offloaded at

different sites. Copies of the manifests should be submitted to the Agency and copies must be kept at the licensed facility where the sludge is generated.

## 5. MONITORING

### 5.1 Introduction to Wastewater Monitoring

Monitoring required under the regulations entail making measurements of flow and effluent parameters at the locations (monitoring points) and at the times indicated in the Regulations or according to the conditions specified in the licence. The analytical methods used to quantify the parameters must be made using the methods specified in the Fifth Schedule of the regulations. The use of any other method will require prior, written approval from NEPA.

The documentation of the monitoring (sample locations, sampling methods, dates and times of sampling, persons that conducted the sampling and the analyses and all intermediate analytical data (calibration curves, quality control samples, standards) must be kept by the licensee or the analytical laboratory for a minimum of five years after the sample is taken.

### 5.2 Sampling Schedule and Frequency

The Regulations (Regulation 18) provides for the application of typical sampling regimes such as those highlighted in Table 5-1 with the parameters to be monitored by sector. The conditions of the licences may specify a different frequency and additional or fewer parameters to be monitored.

**Table 5-1 Sampling Frequency and Parameters to be Monitored by Sector**

<b>Sector</b>	<b>ISIC Rev. 3.1</b>	<b>Frequency for all activities at the facility</b>	<b>Parameters to be monitored unless otherwise specified in Licence</b>
Aquaculture	0502		
Mining of non-ferrous ores (including bauxite)	1320	quarterly	TSS, pH
Other Manufacturing of Food products ≤ 50,000 m <sup>3</sup> /day	15	quarterly	BOD, COD, Oil and Grease, TSS, NO <sub>3</sub> , PO <sub>4</sub> , NH <sub>4</sub>

<b>Sector</b>	<b>ISIC Rev. 3.1</b>	<b>Frequency for all activities at the facility</b>	<b>Parameters to be monitored unless otherwise specified in Licence</b>
Other Manufacturing >50,000 m <sup>3</sup> /day	15*	monthly	pH, COD, TSS, Oil and Grease
Other Manufacturing ≤ 50,000 m <sup>3</sup> /day	15*	quarterly	pH, COD, TSS, Oil and Grease
All others >50,000 m <sup>3</sup> /day	15*	monthly	pH, COD, TSS, Oil and Grease
Manufacture of sugar	1542	monthly during crop (factory grinding sugar cane and/or producing sugar)  Quarterly out of crop (factory <b>not</b> grinding sugar cane and/or producing sugar)	BOD, COD, TSS, NO <sub>3</sub> , PO <sub>4</sub> , Temperature  BOD, COD, TSS, NO <sub>3</sub> , PO <sub>4</sub> ,
Distilling, rectifying and blending of spirits; ethyl alcohol production from fermented materials	1551	monthly	BOD, COD, TSS, NO <sub>3</sub> , PO <sub>4</sub> , Temperature
Manufacture of malt liquors and malt	1553	monthly	BOD, COD, TSS, NO <sub>3</sub> , PO <sub>4</sub> , pH, Oil and Grease, NH <sub>4</sub> , PO <sub>4</sub> , Temperature increase
Other Manufacturing of Food products >50,000 m <sup>3</sup> /day	15xx not previously listed	monthly	BOD, COD, oil and grease, TSS, NO <sub>3</sub> , PO <sub>4</sub> , NH <sub>4</sub>
Tanning and dressing of leather	1911	monthly	BOD, TSS, Oil and Grease, Total Chromium, pH, Sulphide
Manufacture of refined petroleum products	2320	monthly	Temperature, pH, TSS, Ammonia, Total

<b>Sector</b>	<b>ISIC Rev. 3.1</b>	<b>Frequency for all activities at the facility</b>	<b>Parameters to be monitored unless otherwise specified in Licence</b>
			Chromium, Hexavalent Chromium, Sulphide, BOD, COD, Faecal Coliform, Total Coliform, Oil and Grease, Phenols
Manufacture of paints, varnishes and similar coatings, printing ink and mastics	2422	Monthly	pH, Phenols, Oil and Grease, TSS, Pb, Cr, Cu, Ni, Zn, Total Heavy Metals
Manufacture of soap and detergents, cleaning and polishing preparations, perfumes and toilet preparations	2424	Monthly	BOD, COD, TSS, Surfactants, Oil and Grease, pH
Manufacture of cement, lime, plaster	2694	Quarterly  Annual	TSS, Oil and Grease, pH, Temperature, BOD, COD, Faecal Coliform, Total Coliform, Cl, Fe, Mg, Mn, PO <sub>4</sub> , TDS, Zn, Pb, Cd, As, Cr, Cu, Hg, Ni, Se, Ag, Sn
Manufacture of basic precious and non-ferrous metals (includes alumina plants)	2720	Monthly  Every 6 months	Na, SO <sub>4</sub> , pH, Conductivity, COD, Cl, NO <sub>3</sub> , TDS, Fluoride, Oxalate, Fe, Mg, Ca, PO <sub>4</sub> ,  Zn, Cd, Hg, Pb, As, Cr, Cu, Ni, Se, Ag, Sn
Production, transmission and distribution of electricity	4010	quarterly	TSS, Cr, Cu, Ni, Zn, Fe, Oil and Grease, NH <sub>4</sub> , Sulphite; Temperature; Oil and Grease, NO <sub>3</sub> , PO <sub>4</sub> , Free Available Chlorine.



In the event that a sample is missed, i.e., the required sampling frequency is less than specified in the licence, the procedures indicated in Table 5-2 must be used. If scheduled samples are missed, they may be taken later only within the allowable period (i.e. the minimum time between sample collections must be maintained). The minimum time between sample collections is also indicated in Table 5-2.

**Table 5-2 Procedure For Missed Samples**

<b>Sampling Frequency (Minimum Time Between Samples)</b>					<b>Procedure for Missed Samples</b>
Quarterly	Monthly	Fortnightly	Weekly	Daily or continuous	
(2 months)	(18 days)	(8 days)	(4 days)	(15 hours)	
Not applicable	Not applicable	Miss 1 sample	Miss 1 or 2 samples	Miss up to 2.5% of samples or, for continuous monitoring, miss up to 15% of monitoring time	Action ' A' : Replace missing data with the arithmetic mean of data obtained over the previous 12 months.
Not applicable	Miss 1 or 2 samples	Miss 2 or 3 samples	Miss 3 or 4 samples	Miss between 2.5% and 5% of samples or, for continuous monitoring, miss 15-20% of monitoring time	Action ' B' : Replace missing data with the arithmetic mean of data obtained over the previous 12 months + 20%.
Miss any sample	Miss > 2 samples	Miss > 3 samples	Miss > 4 samples	Miss > 5% of samples or, for Continuous monitoring, miss > 20% of monitoring time	Action ' C' : Report failure to collect required samples to DEC Regional Manager within 7 days of failure. Use data from the same time period for the

Sampling Frequency (Minimum Time Between Samples)					Procedure for Missed Samples
					data obtained over the current year + 30%, or the arithmetic mean of the previous 12 months + 30%.

### 5.3 Sample Collection and Preservation

Once a sample is taken, the constituents of the sample must be kept in the same condition as when it was collected. Samples must be properly preserved when it is not possible to analyse collected samples immediately. Preservation will prevent biological activity such as microbial respiration, chemical activity such as precipitation or pH change and physical activity such as aeration.

Methods of preservation include cooling, pH control and adding chemicals to stabilize the sample. Freezing is usually not recommended. The length of time that a constituent in wastewater will remain stable is related to the character of the constituent and the preservation method used. The Handbook for Sampling and Sample Preservation of Water and Wastewater (Environmental Protection Agency 1982) provides detailed guidelines on this topic. These are summarized in Table 5-3. *Standard Methods for the Examination of Water and Wastewater* (Published by the American Public Health Association, American Water Works Association, and Water Environment Federation) also provides information on sample collection and preservation.

### 5.4 Analytical Methods

The Regulations (Fifth Schedule) specify the analytical methods that are to be used to measure the parameters. Details of the methods are provided in the references and will not be repeated here.

Alternate methods may be used provided they are approved by NEPA. Laboratories or licensees that wish to use alternate methods must contact NEPA. References for some of the additional methods that may be appropriate are as follows.

#### Analytical Methods

Code of Federal Regulations Title 40 – Protection of Environment Part 136  
40CFRPart136  
([http://www.access.gpo.gov/nara/cfr/waisidx\\_05/40cfr136\\_05.html](http://www.access.gpo.gov/nara/cfr/waisidx_05/40cfr136_05.html))

Appendix A to 40CFR Part 136--Methods for Organic Chemical Analysis of Municipal and Industrial Wastewater

Appendix B to Part 136--Definition and Procedure for the Determination of the Method Detection Limit--Revision 1.11

Appendix C to Part 136--Inductively Coupled Plasma--Atomic Emission Spectrometric Method for Trace Element Analysis of Water and Wastes Method 200.7

Appendix D to Part 136--Precision and Recovery Statements for Methods for Measuring Metals

EPA 600/4-79-020. Methods for Chemical Analysis of Water and Wastes. Revised March 1983 (NTIS / PB84-128677; CD ROM or NEPIS <http://nepis.epa.gov/Exe/ZyPDF.cgi?Dockey=30000Q10.PDF>)

EPA 600/8-80-038. Manual of Analytical Methods for the Analysis of Pesticides in Humans and Environmental Samples. June 1980. (NTIS / PB82-208752)

EPA 821/B-96-005. Methods for Organic Chemical Analysis of Municipal and Industrial Wastewater. December 1996. (NTIS / PB97-125298 or NEPIS)

Standard Methods for the Examination of Water and Wastewater (Published by the American Public Health Association, American Water Works Association, Water Environment Federation)

### **5.4.1 Record Keeping**

Laboratories that undertake analyses are required to maintain records that must include the following:

- Monitoring ID/name and sufficient information to accurately identify the monitoring location.
- Sample-handling procedures used to ensure the integrity of the sample, e.g., sample date, chain of custody information;
- Results including units of measurement;
- Method(s) used, including sampling and analysis procedure, sample preservation and storage before transfer to the laboratory for analysis;
- name of officer collecting and handling the samples;
- name of laboratory;
- laboratory sample number;
- calibration of equipment;
- quality control and quality assurance procedures

- control charts for standards, analytical balances, sample storage refrigerators, incubators, etc.

Note that the regulations require you to provide the location where such records are kept and NEPA may from time to time require you to provide information.

**Table 5-3 Sampling Containers, Preservation Techniques, and Holding Times**

Parameter	Container <sup>b</sup>	Preservative	Maximum Holding Time
Bacterial Test			
Coliform, faecal and total	Sterilised P,G	Cool, 4°C; 0.008% Na <sub>2</sub> S <sub>2</sub> O <sub>3</sub>	6 hours
Faecal streptococci	Sterilised P,G	Cool, 4°C; 0.008% Na <sub>2</sub> S <sub>2</sub> O <sub>3</sub>	6 hours
Inorganic Tests			
Acidity	P,G	Cool, 4°C	14 days
Alkalinity	P,G	Cool, 4°C	14 days
Ammonia	P,G	Cool, 4°C; H <sub>2</sub> SO <sub>4</sub> to pH < 2	28 days
Biochemical oxygen demand	P,G	Cool, 4°C	48 hours
Biochemical oxygen demand, carbonaceous	P,G	Cool, 4°C	48 hours
Bromide	P,G	None required	28 days
Chemical oxygen demand	P,G	Cool, 4°C; H <sub>2</sub> SO <sub>4</sub> to pH < 2	28 days
Chloride	P,G	None required	28 days
Chlorine, total residual	P,G	None required	Analyse immediately
Colour	P,G	Cool, 4°C	48 hours
Cyanide, total and amenable to chlorination	P,G	Cool, 4°C; NaOH to pH > 12	14 days
Fluoride	P	None required	28 days
Hardness	P,G	HNO <sub>3</sub> to pH < 2	6 months
Hydrogen ion (pH)	P,G	None required	Analyse immediately
Kjeldahl and organic nitrogen	P,G	Cool, 4°C; H <sub>2</sub> SO <sub>4</sub> to pH < 2	28 day
Metals			
Chromium (VI)	P,G	Cool, 4°C	24 hours
Mercury	P,G	HNO <sub>3</sub> to pH < 2	28 days

Parameter	Container <sup>b</sup>	Preservative	Maximum Holding Time
Metals, except above	P,G	HNO <sub>3</sub> to pH < 2	6 months
Nitrate	P,G	Cool, 4°C	48 hours
Nitrate-nitrite	P,G	Cool, 4°C; H <sub>2</sub> SO <sub>4</sub> to pH < 2	28 days
Nitrite	P,G	Cool, 4°C	48 hours
Oil and grease	G	Cool, 4°C; H <sub>2</sub> SO <sub>4</sub> to pH < 2	28 days
Organic carbon	P,G	Cool, 4°C; HCl or H <sub>2</sub> SO <sub>4</sub> to pH < 2	28 days
Orthophosphate	P,G	Filter immediately Cool, 4°C	48 hours
Oxygen, dissolved probe	G	None required	Analyse immediately
Phenols	G	Cool, 4°C; H <sub>2</sub> SO <sub>4</sub> to pH < 2	28 days
Phosphorus (elemental)	G	Cool, 4°C	48 hours
Phosphorus, total	P,G	Cool, 4°C; H <sub>2</sub> SO <sub>4</sub> to pH < 2	28 days
Residue, total	P,G	Cool, 4°C	7 days
Residue, filterable	P,G	Cool, 4°C	7 days
Residue, non-filterable (TSS)	P,G	Cool, 4°C	7 days
Residue, settleable	P,G	Cool, 4°C	48 hours
Residue, volatile	P,G	Cool, 4°C	7 days

P Plastic

G Glass

## 5.5 Flow Measurement

Regulation 17 requires flow measurement at the inlet and outlet of the wastewater treatment facility. The range of instrumentation for flow measurement is large and only some of the most common types are mentioned here. Together with the concentration of the various parameters, the flow is used to estimate the discharge load.

The purpose of this section is to:

- Summarise the methods used to measure flows
- Indicate acceptable methods for measuring flows

- Indicate how flows can be verified in field inspections and in the review of licence applications and renewals
- Provide references for more detailed information

### **5.5.1 Methods for measuring waste water flows**

Wastewater flows occur either in closed channels or open channels.

#### **Closed Channel Flows**

Closed channel flows are defined as those that occur in conduits that are entirely filled with liquid under pressure. Examples are flows between treatment units in a wastewater treatment plant, where liquids and/or sledges are pumped under pressure. There will be relatively few licensees with cases or situations where closed channel flow measurements are applicable for wastewater flow measurement. Such cases will typically occur where wastewater is pumped under pressure immediately prior to discharge from the facility.

Flows in closed channels are measured by inserting a device into the conduit. Examples of closed channel flow measuring devices are the Venturi meter, the Pitot tube, the paddle wheel, the electromagnetic flow meter, Doppler, and the transit-time flow meter. For example, Venturi meters and Pitot tubes relate differential pressure to flow while electromagnetic flow meters relate the induced electric voltage to flow.

#### **Open Channel Flows**

Open channel flow is defined as flow in any channel in which the liquid flows with a free surface. Examples include rivers and irrigation channels. Open channels are used in most sewer systems, sewage treatment plants and industrial waste applications. Note that sewers and underground drains and pipes when flowing partially full and not under pressure, are also classified as open channels. Most of the wastewater (sewage and trade effluent) flows have been observed to be open channels.

Flows in open channels are measured by primary or secondary devices. Primary devices are standard hydraulic structures, such as flumes and weirs, that are inserted in the open channel and accurate flow can be determined from measurements of the depth of liquid (head) at the specific point in the primary device and the (predetermined) geometry of the device.

Secondary devices in conjunction with primary devices can be used to automate the flow measurement. Secondary devices use sensors to measure some property of the wastewater in the primary device and

convert the measurement to a corresponding depth or flow using established mathematical relationships. Examples of secondary devices are floats, ultrasonic transducers, bubblers, and transit-time flow meters. A recorder generally measures the output of the secondary device transmitted to a recorder and/or totaliser to provide instantaneous and historical flow data. Sensor outputs may also be transmitted to sampling systems to facilitate flow proportioning.

There are three methods for automatically measuring open channel flow.

- Hydraulic Structures
- Area Velocity
- Slope-Hydraulic Radius

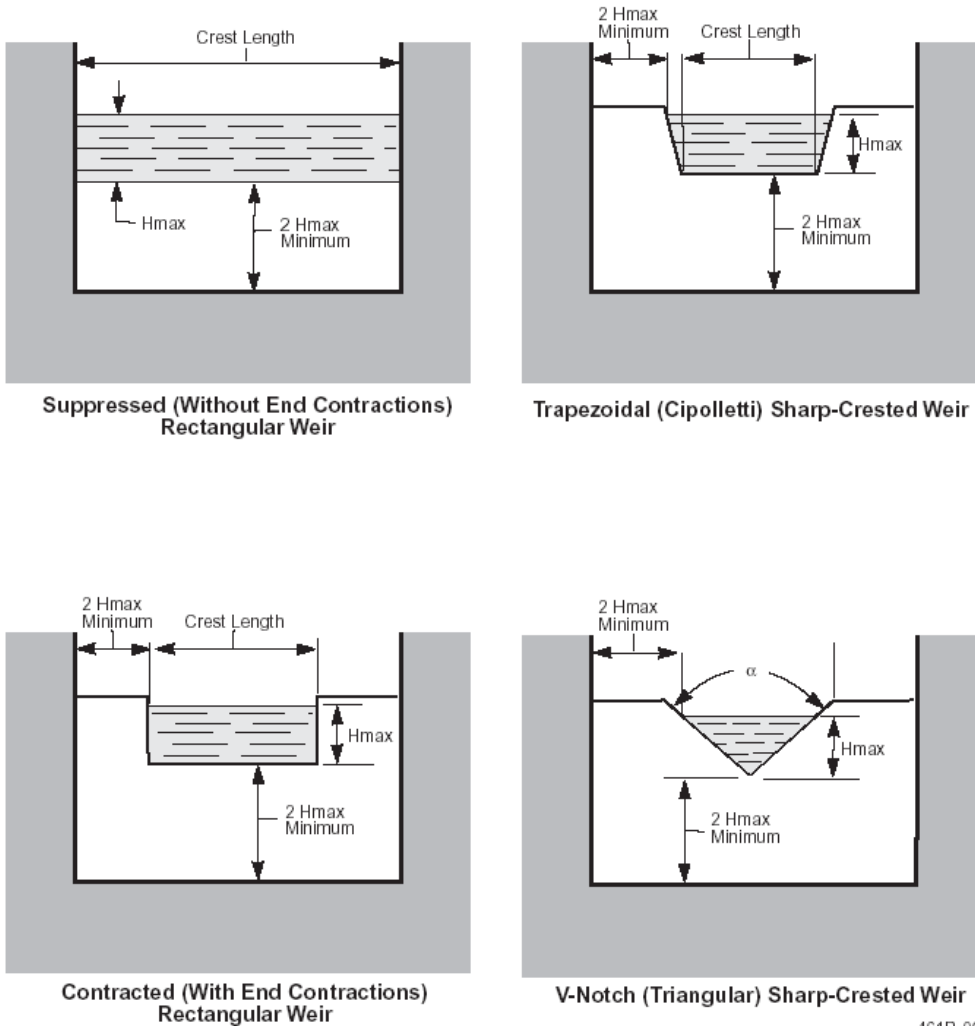
### **Hydraulic Structures**

Weirs and flumes are the two most common methods for measuring flows in open channels. These devices are calibrated restrictions that are inserted into the channel to control the shape and velocity of the flow. The flow rate is then determined by measuring the liquid level in or near the restriction and using the mathematical relationship that relates the flow to the liquid level and the geometry and type of weir.

### **Weirs**

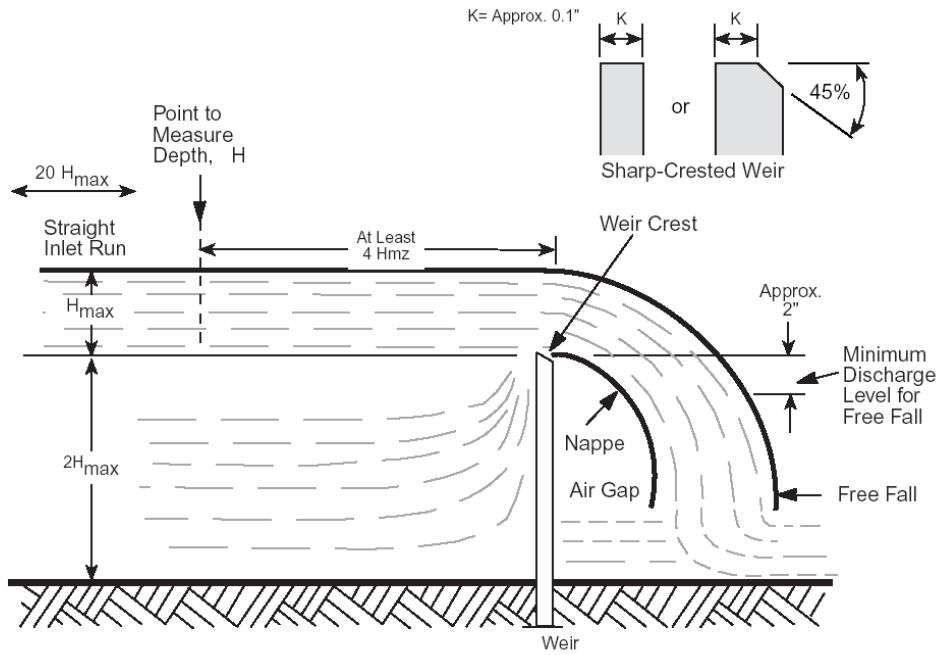
The most common types of weirs are the triangular (or V-notch) weir, the rectangular weir, and the trapezoidal (or Cipolletti) weir (see Figures 5-1 and 5-2). Weirs are generally not suitable for flows with solids that may cling to the weir or are deposited upstream of the device (thereby changing the flow characteristics). Weirs that are constructed with thin plates with a sharp edge over which the water flows are termed sharp-crested weirs. The broad-crested weirs are typically constructed of timber or concrete and the broad edge is typically across the entire width of the stream. Broad-crested weirs need to be calibrated in order to meet accuracy requirements. In contrast, flow rates determined from sharp-crested weirs are accurately given by equations based on the known geometry of the weir and the level of the liquid.

**Figure 5-1** Common Types of Sharp-Crested Weirs (From Appendix G, Supplemental Flow Measurement Information, NPDES Compliance Inspection Manual (1994))





**Figure 5-2 Profile and Nomenclature of Sharp-Crested Weirs (From Appendix G, Supplemental Flow Measurement Information, NPDES Compliance Inspection Manual (1994))**



## Flumes

A flume is a specially shaped open channel flow section providing a restriction in channel area and/or a change in channel slope. The flow rate in the channel is determined by measuring the liquid depth at a specified point in the flume. The most common flume is the Parshall flume (Figure 5-4). The flow rate through a Parshall flume is determined by measuring the liquid level one third of the way into the converging section. Parshall flumes are designated by the width of the throat, which ranges from one inch to 50 feet. The throat width and all other dimensions must be strictly followed so that standard discharge tables can be used. Also, note the drop in the floor of the flume, which makes it difficult to install a Parshall flume in an existing channel.

The Palmer-Bowlus flume (Figure 5-5) is designed to be installed in an existing channel with minimal effort. The flow rate through a Palmer-Bowlus flume is determined by measuring the liquid depth at a point one-half pipe diameter upstream from the flume throat. Palmer-Bowlus flumes are designated by the size of the pipe into which they fit. Standard sizes range from four to 42 inches.

The dimensional configuration is not rigidly established for each flume size. However, a Palmer-Bowlus flume with a trapezoidal throat with a flat bottom has emerged as the standard design for circular pipes.

Flumes are more expensive and more difficult to install than weirs. Common materials of construction include fibreglass, concrete and metal. However, flumes result in a lower head loss and are self-cleaning, requiring less maintenance than a weir.

### **Area Velocity**

The area velocity method calculates flow rate  $Q$ , by multiplying the area,  $A$ , of the flow by its average velocity,  $V$ .

$$Q = A \times V.$$

Most area velocity flow meters use a single sensor to measure flow rate. Doppler ultrasonic is used to measure average flow velocity, while an integral pressure transducer measures the level in the channel. The flow meter converts this level into the area of the flow based on the size and shape of the channel.

The area velocity method can be used to measure flows in open channel, surcharged, full pipe and submerged flows and does not require the installation of a weir or flume.

### **Slope-Hydraulic Radius**

Various resistance equations are used to estimate flow rate based on measurements of the water surface slope, cross sectional area, and wetted perimeter over a length of uniform channel. The most popular of these equations is the Manning formula (Figure 5) which uses a coefficient to correct for the type of channel in use. The cross-sectional area of the flow, the wetted perimeter of the flow and the slope ratio must be calculated. The results are more accurate if the flow cross-section, velocity, depth and slope are constant (steady flow).

$$Q = \frac{K}{n} A R^{2/3} S^{1/2}$$

where:

$Q$  = flow rate

$A$  = cross sectional area of flow

$R$  = hydraulic radius (cross sectional area divided by wetted perimeter)

$S$  = slope of the hydraulic gradient

$n$  = a dimensionless number or roughness coefficient based on channel material and condition that defines the flow resistance of

a unit of bed surface and is a function of particle size, bed shape, and constructional bed forms (e.g., ripples).

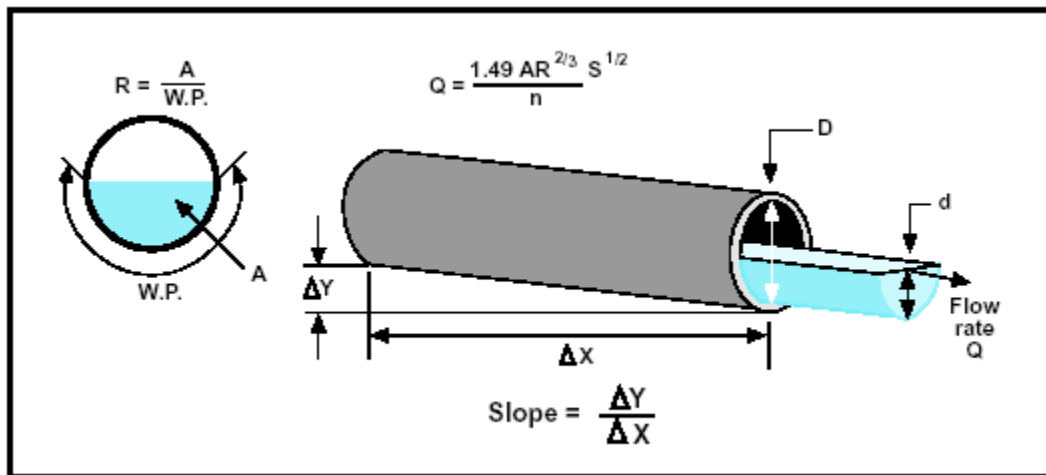
$K$  = constant dependent upon units

The cross-sectional area  $A$  and the hydraulic radius  $R$  are calculated based on the liquid depth, and the size and shape of the channel. The slope  $S$  is often estimated based on installation drawings of the channel. The roughness coefficient  $n$  is selected from standard references based on the material of construction of the channel, and its condition.

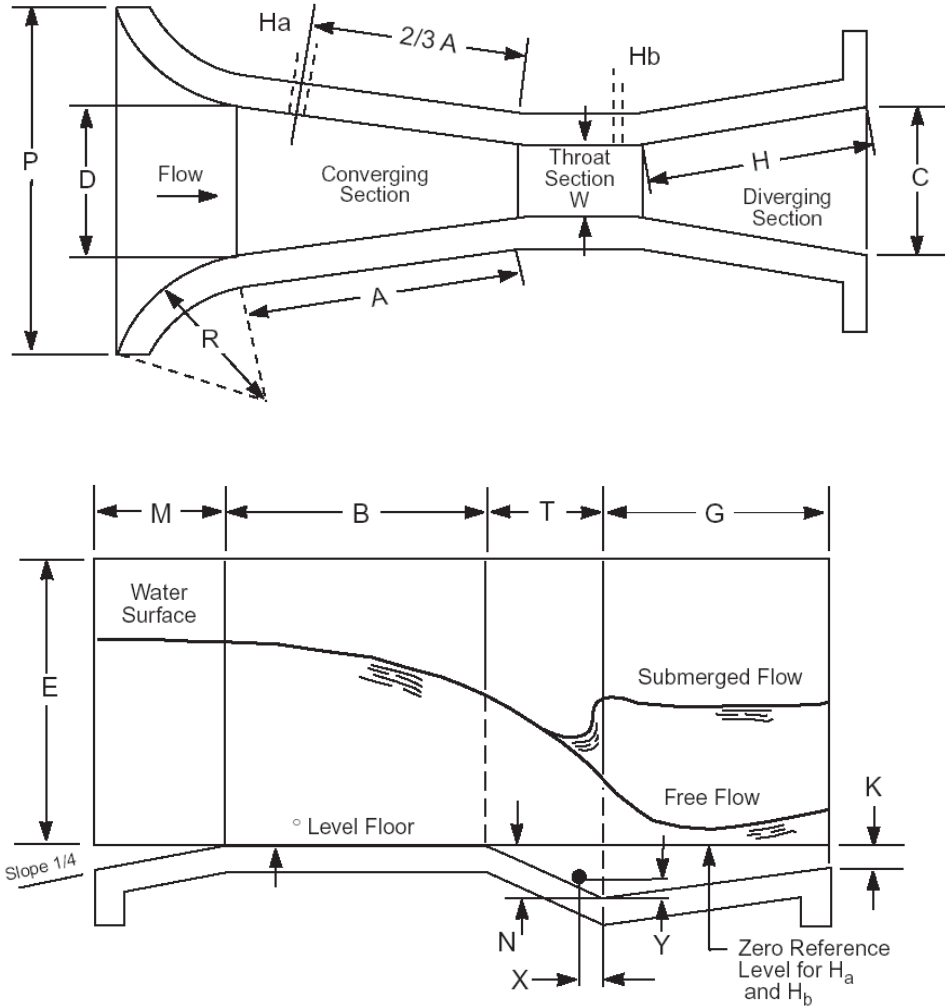
Given the size, shape, slope and roughness of the channel, an open channel flow meter can calculate flow rate using the Manning formula based on a measurement of the liquid depth.

The Manning formula is not as accurate as the hydraulic structures and area velocity methods, but it can provide sufficient accuracy in some applications. In addition, no weir or flume is required.

**Figure 5-3 Manning Formula**

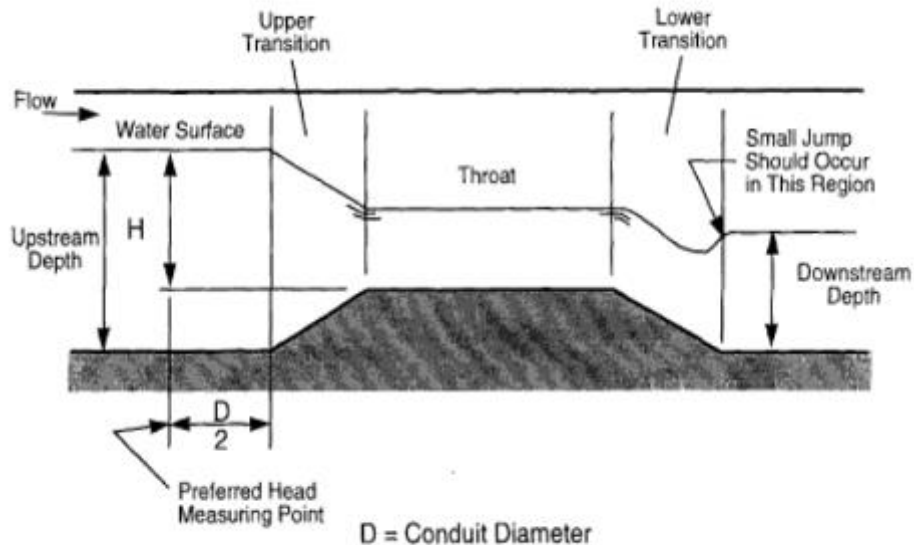


**Figure 5-4 Dimensions and Capacities of Parshall Measuring Flumes for Various Throat Widths (From Appendix G, Supplemental Flow Measurement Information, NPDES Compliance Inspection Manual (1994))**



- W** Width of flume throat.
- A** Length of side wall of converging section.
- 2/3A** Distance back from end of crest to gauge point
- B** Axial length of converging section.
- C** Width of downstream end of flume.
- D** Width of upstream end of flume.
- E** Depth of flume.
- T** Length of flume throat.
- G** Axial length of diverging section.
- H** Length of side wall of the diverging section.
- K** Difference in elevation between lower end of flume and crest.
- M** Length of approach floor.
- N** Depth of depression in throat below crest.
- P** Width between ends of curved wing walls.
- R** Radius of curved wing wall.
- X** Horizontal distance to  $H_b$  gauge point from low point in throat.
- Y** Vertical distance to  $H_b$  gauge point from low point in throat.

**Figure 5-5 Free Flowing Palmer Bowlus Flume From Appendix G, Supplemental Flow Measurement Information, NPDES Compliance Inspection Manual (1994)**



### 5.5.2 Inspection of Flow Measuring Devices

Periodic inspection of the flow measuring devices is essential for proper operation. Some of the key steps are outlined below but **you must rely on the maintenance provided by the manufacturer.**

- Observe the flow patterns near the primary device for excessive turbulence or velocity. The flow lines must be straight.
- Inspect the primary device for evidence of corrosion, scale formation, or solids accumulation that may bias the flow measurement.
- Verify that weirs are level, plumb, and perpendicular to the flow direction.
- Verify that flumes are level, the throat walls (narrowed section of flume) are plumb, and the throat width is the standard size intended.
- Inspect historical records (i.e., strip charts and logs) for evidence of continuous flow measurements.
- If you have a closed channel flow measuring devices verify that the pipe is always full. If these devices are used, then there must be also a means for the regulatory agencies/inspector to

verify the accuracy of these meters. Primary flow measuring devices such as weirs and flumes are ideal for this purpose.

- Calibrates your flow meters across the full range of expected flows.

### **5.5.2.1 Additional Information Sources**

Information on flow measuring devices can be obtained from the following sources:

Associated Water and Air Resource Engineers, Inc. 1973. Handbook for Industrial Wastewater Monitoring. USEPA, Technology Transfer. EPA 625/6-73-002 NTIS: PB-259146

Eli, R., and H. Pederson. 1979. Calibration of a 90° V-Notch Weir Using Parameters Other than Upstream Head. EPA-61809A-2B.

ISCO®. 1985. Open Channel Flow Measurement Handbook, Lincoln, Nebraska. (Contains tables of various flow measurement devices.)

King, H.W., and E.F. Brater. 1963. Handbook of Hydraulics. 5th ed. New York: McGraw-Hill Book Co. (contains tables of various flow measurement devices.)

Metcalf & Eddy, Inc. 1972. Wastewater Engineering. New York: McGraw Hill Book Co.

Robinson, A.R. 1965. Simplified Flow Corrections for Parshall Flumes Under Submerged Conditions, Civil Engineering, ASCE.

Shelley, P.E., and G.A. Kirkpatrick. 1975. Sewer Flow Measurement; A State of the Art Assessment, U.S. Environmental Protection Agency, EPA-600/2-75-027.

Simon, A. 1976. Practical Hydraulics. New York: John Wiley & Sons.

Stevens. Water Resources Data Book, Beaverton, Oregon. (Contains tables of various flow measurement devices.)

Thorsen, T., and R. Oden. 1975. "How to Measure Industrial Wastewater Flow," Chemical Engineering, 82(4): 95-100.

U.S. Department of Commerce, National Bureau of Standards. 1975. A Guide to Methods and Standards for the Measurement of Water Flow. COM-75-10683.

U.S. Department of the Interior (USDI), Bureau of Reclamation. 1967. Water Measurement Manual, 2nd Ed. (Contains tables of various flow measurement devices.)

U.S. Environmental Protection Agency, Office of Water Enforcement and Permits Enforcement Division. September 1981. NPDES Compliance Flow Measurement Manual.

Blaso, L. 1975. "Flow Measurement Under Any Conditions," *Instruments and Control Systems*, 48(2): 45-50.

Bos, M.G. 1976. Discharge Measurement Structures, Working Group on Small Hydraulic Structures International Institute for Land Reclamation and Improvement, Wageningen, The Netherlands.

Mauis, F.T. 1949. "How to Calculate Flow Over Submerged Thin-Plate Weirs." *Eng. News-Record*. p. 65.

Smoot, G.F. 1974. A Review of Velocity-Measuring Devices. U.S. Department of the Interior (USDI), United States Geological Survey (USGS). Open File Report, Reston, Virginia.

## **5.6 Guidelines For Monitoring Industrial and Sewage Sludge**

### **5.6.1 Industrial Sludge**

Samples collected using the sampling protocols listed below, for sampling waste with properties similar to the indicated materials, will be considered to be representative of the waste.

Extremely viscous liquid -- ASTM Standard D140-70 Crushed or powdered material -- ASTM Standard D346-75 Soil or rock-like material -- ASTM Standard D420-69 Soil-like material -- ASTM Standard D1452-65

Containerised liquid wastes -- "COLIWASA" described in "Test Methods for the Evaluation of Solid Waste, Physical/Chemical Methods," \* U.S. Environmental Protection Agency, Office of Solid Waste, Washington, DC 20460. [Copies may be obtained from Solid Waste Information, U.S. Environmental Protection Agency, 26 W. St. Clair St., Cincinnati, Ohio 45268]<sup>2</sup>

Liquid waste in pits, ponds, lagoons, and similar reservoirs. -- "Pond Sampler" described in "Test Methods for the Evaluation of Solid Waste, Physical/Chemical Methods."<sup>3</sup>

---

<sup>2</sup> These methods are also described in "Samplers and Sampling Procedures for Hazardous Waste Streams," EPA 600/2-80-018, January 1980.

<sup>3</sup> This manual also contains additional information on application of these protocols.

## 5.6.2 Sewage Sludge

Sampling and analysis methods for sewage sludge are needed to determine nutrient levels, trace elements and most importantly to determine pathogen and vector attraction levels. The analyses must include all of the parameters specified in the biosolids standards. Analyses must be done prior to land application to determine compliance with the Regulations, based on the intended final disposal.

Analysis Methods listed below can be used to analyse samples of sewage sludge.

(1) *Enteric viruses*. ASTM Designation: D 4994-89, "Standard Practice for Recovery of Viruses From Wastewater Sludges", 1992 Annual Book of ASTM Standards: Section 11-Water and Environmental Technology, ASTM, 1916 Race Street, Philadelphia, PA 19103-1187.

(2) *Faecal coliform*. Part 9221 E. or Part 9222 D., "Standard Methods for the Examination of Water and Wastewater", 18th Edition, 1992, American Public Health Association, 1015 15th Street, NW., Washington, DC 20005.

(3) *Helminth ova*. Yanko, W.A., "Occurrence of Pathogens in Distribution and Marketing Municipal Sludges", EPA 600/1-87-014, 1987. National Technical Information Service, 5285 Port Royal Road, Springfield, Virginia 22161 (PB 88-154273/AS).

(4) *Inorganic pollutants*. "Test Methods for Evaluating Solid Waste, Physical/Chemical Methods", EPA Publication SW-846, Second Edition (1982) with Updates I (April 1984) and II (April 1985) and Third Edition (November 1986) with Revision I (December 1987).<sup>5</sup>

---

<sup>4</sup> Note: The TCLP (Method 1311) is published in "Test Methods for Evaluating Solid Waste, Physical/Chemical Methods," EPA Publication SW-846

<sup>5</sup> Available online at <http://www.epa.gov/waste/hazard/testmethods/sw846/online/index.htm>



(5) *Salmonella sp. bacteria*. Part 9260 D., "Standard Methods for the Examination of Water and Wastewater", 18th Edition, 1992, American Public Health Association, 1015 15th Street, NW., Washington, DC 20005; or

Kenner, B.A. and H.P. Clark, "Detection and enumeration of *Salmonella* and *Pseudomonas aeruginosa*", Journal of the Water Pollution Control Federation, Vol. 46, no. 9, September 1974, pp. 2163-2171. Water Environment Federation, 601 Wythe Street, Alexandria, Virginia 22314.

(6) *Specific oxygen uptake rate*. Part 2710 B., "Standard Methods for the Examination of Water and Wastewater", 18th Edition, 1992, American Public Health Association, 1015 15th Street, NW., Washington, DC 20005.

(7) *Total, fixed, and volatile solids*. Part 2540 G., "Standard Methods for the Examination of Water and Wastewater", 18th Edition, 1992, American Public Health Association, 1015 15th Street, NW., Washington, DC 20005.

## 6. ESTIMATING EFFLUENT LOADS AND DISCHARGE FEES

### 6.1 General Principles of Measuring Loads

#### 6.1.1 Using Lab Monitoring Results with Flow Rate Measurement

The method requires continuous or semi continuous measurements of the volume of the effluent discharged over a period of time. This measurement is then used to determine the average daily flow rate. Laboratory testing of the effluent concentration for the parameters in the discharge Licence and at the frequency required in the discharge licence is also required. It can therefore be seen, that the more rigorous the sampling regime is for effluent quality and quantity, the more accurate the effluent loads can be reported.

#### Box 1 Sample Calculation 1- Direct measurement

##### Sample Calculation 1- Direct measurement

##### Calculating the COD load

The average COD in the trade effluent from facility **W** is 37 mg/L

The facility has an average daily flow of 25,000 m<sup>3</sup>/day.

1 cubic metre = 1,000 L

25,000 m<sup>3</sup>/day x 1000

=25,000,000 L/day

The release of COD is 37 mg/L x 25,000,000 L/day

=925,000,000 mg/day x 365 day/year

=337,625,000,000 mg/year

1 tonne = 10<sup>9</sup> mg

= 337.625 tonnes/y

## 6.2 Discharge Fees

### 6.2.1 Components of the Discharge Fee

The discharge fee comprises three (3) different elements which may include a discount for beneficial use.

#### ***Monitoring & Inspection (Administration) Fee (Sixth Schedule Part D)***

This fee, which will be determined by NEPA, includes cost for direct labour hours and materials that involve site visits over a five year period, travelling costs among others. One fifth of this cost would be applied to the annual discharge fee.

#### ***Pollutant Load and Volume***

The waste strength in sewage and/or trade effluent discharges based on the concentration level of the licensed pollutants will be used in calculating the fee as well as the volume of the sewage and/or trade effluent.

Measurements of the daily flow rates along with laboratory monitoring results for each pollutant would be used to determine the annual pollutant Load as described in Chapter 5. Each pollutant has a dollar value attached to it as shown in the Table 5-1 below.

**Table 6-1 Parameter Fees (Sixth Schedule of Regulations, Part B)**

<b>Pollutant</b>	<b>Fee J\$/tonne</b>
BOD <sub>5</sub>	300
COD <sup>#</sup>	150
Total N	500
Total P	500
Oil and grease	500
TSS	150
Total heavy metals (As, Cd, Cr, Cu, Pb, Hg, Se, Zn)	3,000
As	300
Cd	7500
Cr	500
Cu	200
Pb	700
Hg	20,000
Se	1500
Zn	100
Faecal coliform	
(a) 200 to 5 000 organisms per 100 ml	1,000
(b) 5 000 to 20 000 organisms per 100 ml	2,000
(c) more than 20 000 organisms per 100 ml	3,000

\* For Faecal Coliform the fee rate is in \$/1,000,000 litres

# Use only if no BOD measurement is available

The parameters to be used in calculating discharge fees for Sewage effluent are *Biological Oxygen Demand (BOD), Total Phosphorous (P), Phosphate, Total Nitrogen (N), Total Suspended Solids (TSS) and Faecal Coliform*.

The parameters to be used for Trade effluent are: *Chemical Oxygen Demand (COD), Phosphate, Faecal Coliform, Oil and Grease, Total Phosphorous, Total Suspended Solids, Heavy metals & Total Heavy Metals*.

For combined sewage and trade effluent the parameters to be used are *BOD, COD, TSS, Oil and Grease, Faecal Coliform, Total Heavy Metals, Total Nitrogen, Phosphate and Total Phosphorus*.

### **6.2.2 Receptor Factor**

The receptor is the receiving environment in which the wastewater is being discharged. Five (5) classes have been assigned based on the receiving environment and are as follows:

Class	I	Ground Water
	II	Surface water
	III	Sensitive Marine Systems
	IV	Enclosed and semi-enclosed water bodies
	V	Open Sea

Specific 'weighting criteria' were used to assess the relative levels of risk and impacts to these receptors. The open sea receptor with a zero weighting factor, due to the capacity for complete mixing and therefore dissipation of treated effluent, was used as a baseline.

#### **Table 6-2 Weighting Criteria**

<b>CRITERIA<sup>6</sup></b>	Surface Water	Groundwater	Sensitive Marine Waters	Enclosed (& semi-enclosed) water bodies
Persistency	0	2	2	4
Potential for causing eutrophication	2	1	4	4
Impact on, and risks to, health	2	1	1	2
Potential for migration to other receptors	3	2	2	1
Risks of undesirable changes in the marine ecosystem, irreversibility or durability of effects	3	1	4	4
Negative impacts on marine life and the sustainable development of living resources or on other legitimate uses of the sea	3	1	4	4
<b>Weighting factor (receptor value / total)</b>	0.5	0.3	0.7	0.8

**Risk Based Weighting of Criteria:**

<b>None</b>	<b>0</b>
<b>Low</b>	<b>1</b>
<b>Medium</b>	<b>2</b>
<b>High</b>	<b>3</b>
<b>Very High</b>	<b>4</b>

**The resulting receptor weightings, as shown in Table 6-3, reflect the relative harmfulness of the pollutant to the receiving environment and incorporate costs to society/environment to be paid by licensee based on where the outfall is located.**

---

<sup>6</sup> Source: Convention for the Protection and Development of the Marine Environment of the Wider Caribbean Region, UNEP CEP 2002

**Table 6-3 Receptor Weight Relationship (Sixth Schedule of Regulations, Part D)**

<b>Receptor</b>	<b>Weighting Factor, f</b>	<b>Comment</b>
Open Sea	0	Areas outside reefs with depths of at least 50m and 100m from the shore or reef
Ground water	0.3	
Surface water (including dry gully)	0.5	Streams, rivers, Wetlands, watercourses, Gullies
Sensitive marine waters	0.7	Coastal waters inside reefs
Enclosed (and semi-enclosed) water bodies	0.8	Harbours, ponds

***Discount for the beneficial use of the discharge and/ or sludge generated***

In order to promote the beneficial use of effluent and treated sludge, the regulations include allowances for discounts for the use of effluent or sludge that meets specified standards to be used for irrigation or soil amelioration (Third Schedule Tables 4 and 5) . Other beneficial uses will be considered on a case by case basis.

The discount which applies to nutrients (nitrate and phosphate as well as BOD<sub>5</sub> as a surrogate for organic material carbon). The discounts will be made provided the facility has an approved Nutrient Management Plan and the effluent is demonstrated not to pose any risk to the environment.

**6.3 Estimation of Discharge Fees (including incentives)**

The method for calculating the annual load is specified in the Sixth Schedule.

The key requirements for calculating the load are that:

- for every sampling exercise there should be a concentration measurement,  $C_i$ , for each parameter
- flow rates  $F_i$  and hence volumes  $V_i$  calculations should be carried out for each calendar year or part thereof

**Calculation of load**

For each pollutant,  $p$ , the load (in kilograms) for the calendar year is calculated by averaging the concentrations and multiplying this by the total volume that is discharge for the year (or part thereof) Pollutant

Load =  $[C_{i1} + C_{i2} + \dots + C_{ix}] / x \times$  Total Volume Discharged (for the year or part thereof) ..... **Equation 1**

**Calculation of discharge fee**

The load for each pollutant is multiplied by the per kilogram discharge fee rate and summed to give the base discharge fee,  $B$  (see equation 2).

$$B = \sum_1^p L_p R_p \dots \dots \dots \text{Equation 1}$$

The per tonne pollutant discharge fees are shown in Table 5.2.

The regulations make provisions for amending the discharge fee based on the nature of the receiving environment or receptor,  $x$ , into which the discharge occurs. The weighting factor,  $f$ , is such that discharges to receptors where impacts are of greater concern attract higher fees (see Table 5-4).

Incorporating the fee for monitoring and inspection (M.I), the receptor weighting factor ( $f$ ) and the discount for beneficial use of the effluent and /or sludge ( $U$ ), **equation 3** is derived:

**DF= M.I. + B (1+f) – U** .....**Equation 3**

The complete formula is given as:

**Monitoring & Inspection Fee** (M.I.) (\$) + {**Pollutant load** (tonne/yr) x **Parameter fee** (\$/tonne) [1+ **Environmental receptor weighting factor** ( $f$ )]} – **Beneficial Use** ( $U$ )

Where U= **Load used** (tonne/yr) x **Parameter fee** (\$/tonne)

### Box 2 Sample Calculation 2

#### Sample Calculation 2

Sewage treatment plant discharging 9,463.53 m<sup>3</sup> effluent per day discharging into a surface water body. The parameters in its licence and their concentrations after treatment (i.e. at outfall) are as follows

BOD – 15 mg/L  
 TSS – 15 mg/L  
 Total Nitrogen – 10 mg /L  
 Phosphates – 4 mg/L  
 Chemical Oxygen Demand (COD) – 100 mg/L  
 Oil & Grease – 10 mg/L  
 Faecal Coliform – 12 MPN/100 ml

The monitoring and inspection fee (M.I.) is \$20,000. 20 per cent of the effluent is re-used for irrigation

**First calculate the effluent discharged per year and convert to litres**

$$9,463.53 \times 365 \times 10^3 = 3,454,188,450 \text{ L}$$

**Then calculate and convert loads to tonnes per year**

$$\text{BOD} = (15 \times 3,454,188,450) \times 10^{-9} = 51.8 \text{ tonne/year}$$

$$\text{TSS} = (15 \times 3,454,188,450) \times 10^{-9} = 51.8 \text{ tonne/year}$$

$$\text{Total Nitrogen} = (10 \times 3,454,188,450) \times 10^{-9} = 30.5$$

$$\text{Phosphates} = (4 \times 3,454,188,450) \times 10^{-9} = 13.8$$

**Identify weighting factor and add 1**

$$0.5 + 1 = 1.5$$

**Calculate and convert loads to tonnes per year for beneficial use**

$$\text{BOD} = [15 \times (3,454,188,450 \times 0.2)] \times 10^{-9} = 10.4 \text{ tonne/year}$$

$$\text{Total Nitrogen} = [(10 \times 3,454,188,450) \times 0.2] \times 10^{-9} = 6.9 \text{ tonne/year}$$

$$\text{Phosphates} = [(4 \times 3,454,188,450) \times 0.2] \times 10^{-9} = 2.76 \text{ tonne/year}$$

$$\text{DF} = \$20,000 + \{[(51.8 \times 300 \text{ BOD}) + (51.8 \times 150 \text{ TSS}) + (30.5 \times 500 \text{ N}) + (13.8 \times 500 \text{ P}) + (\$0 \text{ Faecal Coliform}) \times 1.5\} - [(10.4 \times 300) + (6.9 \times 500) + (2.76 \times 500)]$$

$$= (\$20,000 + \$68,190) - \$7950$$

$$= \mathbf{\$80,240/yr}$$

### Box 3 Sample Calculation 3

#### Sample Calculation 3

A waste water treatment plant discharging 290,880 L effluent per day into a surface water body. The parameters in its licence and their concentrations after treatment (i.e. at outfall) are as follows:

BOD – 19mg/L  
 Ammonia - 1 mg/L  
 Iron – 2 mg/L





## **7. APPENDICES**

List of Appendices:

Appendix 1: ISIC Codes and Descriptions

Appendix 2: Template of Monthly Nutrient Management Report

Appendix 3: Template of Overview Format for Pollutant Release and Transfer Register (PRTR) Facility Report

Appendix 4: Template of Detailed PRTR Facility Report

Appendix 5: Template of the Quarterly/Annual Industrial Sludge Report

Appendix 6: Summary Table for Load Calculation

## Appendix 1: ISIC Codes and Descriptions

A partial list of ISIC codes that includes those most likely to be relevant to these regulations is given in Appendix 6.2. The full listing (see the link provided) must be consulted if the activity is not included in the four digit list. Note that a facility may be carrying out activities that require more than one ISIC code and in such cases all such codes must be listed starting with the activity that accounts for the greatest potential for environmental releases.

ISIC Rev.3.1  
 (<http://unstats.un.org/unsd/cr/registry/regcst.asp?Cl=17>)

**Table 7-1 Selected Four Digit ISIC Codes (those likely to be most relevant for these Regulations)**

Code	Description
1010	Mining and agglomeration of hard coal
1020	Mining and agglomeration of lignite
1030	Extraction and agglomeration of peat
1110	Extraction of crude petroleum and natural gas
1120	Service activities incidental to oil and gas extraction excluding surveying
1200	Mining of uranium and thorium ores
1310	Mining of iron ores
1320	Mining of non-ferrous metal ores, except uranium and thorium ores
1410	Quarrying of stone, sand and clay
1421	Mining of chemical and fertilizer minerals
1422	Extraction of salt
1429	Other mining and quarrying n.e.c.
1511	Production, processing and preserving of meat and meat products
1512	Processing and preserving of fish and fish products
1513	Processing and preserving of fruit and vegetables
1514	Manufacture of vegetable and animal oils and fats
1520	Manufacture of dairy products
1531	Manufacture of grain mill products
1532	Manufacture of starches and starch products
1533	Manufacture of prepared animal feeds
1541	Manufacture of bakery products
1542	Manufacture of sugar
1543	Manufacture of cocoa, chocolate and sugar confectionery
1544	Manufacture of macaroni, noodles, couscous and similar farinaceous products
1549	Manufacture of other food products n.e.c.
1551	Distilling, rectifying and blending of spirits; ethyl alcohol production from fermented materials

<b>Code</b>	<b>Description</b>
1552	Manufacture of wines
1553	Manufacture of malt liquors and malt
1554	Manufacture of soft drinks; production of mineral waters
1600	Manufacture of tobacco products
1711	Preparation and spinning of textile fibres; weaving of textiles
1712	Finishing of textiles
1721	Manufacture of made-up textile articles, except apparel
1722	Manufacture of carpets and rugs
1723	Manufacture of cordage, rope, twine and netting
1729	Manufacture of other textiles n.e.c.
1730	Manufacture of knitted and crocheted fabrics and articles
1810	Manufacture of wearing apparel, except fur apparel
1820	Dressing and dyeing of fur; manufacture of articles of fur
1911	Tanning and dressing of leather
1912	Manufacture of luggage, handbags and the like, saddlery and harness
1920	Manufacture of footwear
2010	Sawmilling and planing of wood
2021	Manufacture of veneer sheets; manufacture of plywood, laminboard, particle board and other panels and boards
2022	Manufacture of builders' carpentry and joinery
2023	Manufacture of wooden containers
2029	Manufacture of other products of wood; manufacture of articles of cork, straw and plaiting materials
2101	Manufacture of pulp, paper and paperboard
2102	Manufacture of corrugated paper and paperboard and of containers of paper and paperboard
2109	Manufacture of other articles of paper and paperboard
2211	Publishing of books, brochures and other publications
2212	Publishing of newspapers, journals and periodicals
2213	Publishing of music
2219	Other publishing
2221	Printing
2222	Service activities related to printing
2230	Reproduction of recorded media
2310	Manufacture of coke oven products
2320	Manufacture of refined petroleum products
2330	Processing of nuclear fuel
2411	Manufacture of basic chemicals, except fertilizers and nitrogen compounds
2412	Manufacture of fertilizers and nitrogen compounds
2413	Manufacture of plastics in primary forms and of synthetic rubber
2421	Manufacture of pesticides and other agrochemical products
2422	Manufacture of paints, varnishes and similar coatings, printing ink

<b>Code</b>	<b>Description</b>
	and mastics
2423	Manufacture of pharmaceuticals, medicinal chemicals and botanical products
2424	Manufacture of soap and detergents, cleaning and polishing preparations, perfumes and toilet preparations
2429	Manufacture of other chemical products n.e.c.
2430	Manufacture of man-made fibres
2511	Manufacture of rubber tyres and tubes; retreading and rebuilding of rubber tyres
2519	Manufacture of other rubber products
2520	Manufacture of plastics products
2610	Manufacture of glass and glass products
2691	Manufacture of non-structural non-refractory ceramic ware
2692	Manufacture of refractory ceramic products
2693	Manufacture of structural non-refractory clay and ceramic products
2694	Manufacture of cement, lime and plaster
2695	Manufacture of articles of concrete, cement and plaster
2696	Cutting, shaping and finishing of stone
2699	Manufacture of other non-metallic mineral products n.e.c.
2710	Manufacture of basic iron and steel
2720	Manufacture of basic precious and non-ferrous metals
2731	Casting of iron and steel
2732	Casting of non-ferrous metals
2811	Manufacture of structural metal products
2812	Manufacture of tanks, reservoirs and containers of metal
2813	Manufacture of steam generators, except central heating hot water boilers
2891	Forging, pressing, stamping and roll-forming of metal; powder metallurgy
2892	Treatment and coating of metals; general mechanical engineering on a fee or contract basis
2893	Manufacture of cutlery, hand tools and general hardware
2899	Manufacture of other fabricated metal products n.e.c.
2911	Manufacture of engines and turbines, except aircraft, vehicle and cycle engines
2912	Manufacture of pumps, compressors, taps and valves
2913	Manufacture of bearings, gears, gearing and driving elements
2914	Manufacture of ovens, furnaces and furnace burners
2915	Manufacture of lifting and handling equipment
2919	Manufacture of other general-purpose machinery
2921	Manufacture of agricultural and forestry machinery
2922	Manufacture of machine tools
2923	Manufacture of machinery for metallurgy
2924	Manufacture of machinery for mining, quarrying and construction

<b>Code</b>	<b>Description</b>
2925	Manufacture of machinery for food, beverage and tobacco processing
2926	Manufacture of machinery for textile, apparel and leather production
2927	Manufacture of weapons and ammunition
2929	Manufacture of other special-purpose machinery
2930	Manufacture of domestic appliances n.e.c.
3000	Manufacture of office, accounting and computing machinery
3110	Manufacture of electric motors, generators and transformers
3120	Manufacture of electricity distribution and control apparatus
3130	Manufacture of insulated wire and cable
3140	Manufacture of accumulators, primary cells and primary batteries
3150	Manufacture of electric lamps and lighting equipment
3190	Manufacture of other electrical equipment n.e.c.
3210	Manufacture of electronic valves and tubes and other electronic components
3220	Manufacture of television and radio transmitters and apparatus for line telephony and line telegraphy
3230	Manufacture of television and radio receivers, sound or video recording or reproducing apparatus, and associated goods
3311	Manufacture of medical and surgical equipment and orthopaedic appliances
3312	Manufacture of instruments and appliances for measuring, checking, testing, navigating and other purposes, except industrial process control equipment
3313	Manufacture of industrial process control equipment
3320	Manufacture of optical instruments and photographic equipment
3330	Manufacture of watches and clocks
3410	Manufacture of motor vehicles
3420	Manufacture of bodies (coachwork) for motor vehicles; manufacture of trailers and semi-trailers
3430	Manufacture of parts and accessories for motor vehicles and their engines
3511	Building and repairing of ships
3512	Building and repairing of pleasure and sporting boats
3520	Manufacture of railway and tramway locomotives and rolling stock
3530	Manufacture of aircraft and spacecraft
3591	Manufacture of motorcycles
3592	Manufacture of bicycles and invalid carriages
3599	Manufacture of other transport equipment n.e.c.
3610	Manufacture of furniture
3691	Manufacture of jewellery and related articles
3692	Manufacture of musical instruments
3693	Manufacture of sports goods
3694	Manufacture of games and toys

<b>Code</b>	<b>Description</b>
3699	Other manufacturing n.e.c.
3710	Recycling of metal waste and scrap
3720	Recycling of non-metal waste and scrap
4010	Production, transmission and distribution of electricity
4020	Manufacture of gas; distribution of gaseous fuels through mains
4030	Steam and hot water supply
4100	Collection, purification and distribution of water
4510	Site preparation
4520	Building of complete constructions or parts thereof; civil engineering
4530	Building installation
4540	Building completion
4550	Renting of construction or demolition equipment with operator
5010	Sale of motor vehicles
5020	Maintenance and repair of motor vehicles
5030	Sale of motor vehicle parts and accessories
5040	Sale, maintenance and repair of motorcycles and related parts and accessories
5050	Retail sale of automotive fuel
5260	Repair of personal and household goods
5510	Hotels; camping sites and other provision of short-stay accommodation
5520	Restaurants, bars and canteens
6010	Transport via railways
6021	Other scheduled passenger land transport
6022	Other non-scheduled passenger land transport
6023	Freight transport by road
6030	Transport via pipelines
6110	Sea and coastal water transport
6120	Inland water transport
6210	Scheduled air transport
6220	Non-scheduled air transport
6301	Cargo handling
6302	Storage and warehousing
6303	Other supporting transport activities
6304	Activities of travel agencies and tour operators; tourist assistance activities n.e.c.
6309	Activities of other transport agencies
6411	National post activities
6412	Courier activities other than national post activities
6420	Telecommunications
9000	Sewage and refuse disposal, sanitation and similar activities

## Appendix 2: Template of Monthly Nutrient Management Report

Plant Name	<i>The name of the facility (same as in Licence)</i>
Plant ID	<i>This is the plant ID on the licence</i>
Location of Plant	<i>Indicate the address of the plant</i>
Report date	<i>Enter the date on which you submitted the report</i>
Reporting period	<i>Indicate the period (month/year) for which data are provided. Note: Be sure to provide a continuous (i.e., without any gaps in dates) period for the entire year.</i>
NRCA Wastewater & Sludge Licence	<i>Indicate the NEPA Licence (under these regulations or the P&amp;L Regulations if applicable)</i>
Total Fertilizer Applied (tonnes)	
Incentive for using trade effluent as fertilizer (reconciliation of discharge fees)	

### Nutrient Application Report

Add as many columns as needed for each application (applicn) of nutrient to fields

PARAMETER	Units	Applicn 1	Applicn 2	Applicn 3	Applicn 4	Applicn 5	Monthly Load (kg)
1. Field ID							
2. Crop							
<b>Effluent Applied</b>							
3. Flow rate	m <sup>3</sup> /h						
4. Start date							
5. End date							
6. Volume applied	m <sup>3</sup>						
7. BOD	mg/L						
8. Nitrate as NO <sub>3</sub>	mg/L						
9. Phosphate as PO <sub>4</sub>	mg/L						
10. Faecal Coliform	MPN/100 ml						
11. pH							
12. Temperature	°C						
13. Total Coliform	MPN/100 ml						
14. Total dissolved	mg/L						



solids							
15.Total suspended solids	mg/L						
<b>Biosolids Applied</b>							
16.Start date & hour							
17.End date & hour							
18.Volume/Weight applied	(specify kg or m <sup>3</sup> )						
19.BOD	mg/L						
20.Nitrate as NO <sub>3</sub>	mg/L						
21.Phosphate as PO <sub>4</sub>	mg/L						
22.Other measurement (specify)							
23.Other measurement (specify)							
24.Other measurement (specify)							
25.Other (specify)							
<b>Other Fertilizer applied</b>							
26.Start date & hour							
27.End date & hour							
28.Volume/Weight applied							
29.N							
30.P							
31.K							
32.Other (specify)							
33.Other							
34.Other							
35.Other							

## Appendix 3: Template of Overview Format for Pollutant Release and Transfer Register (PRTR) Facility Report

NATIONAL ENVIRONMENT AND PLANNING AGENCY (NEPA) POLLUTION REGISTER				
FACILITY POLLUTION PREVENTION AND RELEASE INFORMATION				
	Reporting Year			
Overview Report				
Facility Name:				
Address				
Address1				
Address2				
Parish				
Location	Latitude(dd ss.xx):	mm		JAD2001
Location	Longitude (ddmmss.xx):			
Public Contact:				
Public Contact (Phone):			Fax:	
Public Contact Email:				
Web Address:				
Number of Employees:				
Main Activities:				
North American Industrial Classification (ISIC) Code(s)				

<b>NATIONAL ENVIRONMENT AND PLANNING AGENCY (NEPA) POLLUTION REGISTER</b>		
<b>FACILITY POLLUTION PREVENTION AND RELEASE INFORMATION</b>		
	<b>Reporting Year</b>	
<b>Overview Report</b>		
<b>OVERVIEW OF POLLUTANT RELEASES</b>		
<b>Reporting Year</b>		
<b>Medium to which pollutants are released</b>	<b>Compliance with applicable standards, targets or guidelines</b>	
<b>Air</b>		
<b>Water</b>		

**NATIONAL ENVIRONMENT AND PLANNING AGENCY (NEPA)  
POLLUTION REGISTER**

**FACILITY POLLUTION PREVENTION AND RELEASE INFORMATION**

**Reporting Year**

**Overview Report**

**Land**

<b>NATIONAL ENVIRONMENT AND PLANNING AGENCY (NEPA)</b>	
<b>POLLUTION REGISTER</b>	
<b>FACILITY POLLUTION PREVENTION AND RELEASE INFORMATION</b>	
	<b>Reporting Year</b>
<b>Overview Report</b>	
<b>PRE-TREATMENT</b> <i>(indicate how floatables are disposed, quantities and types)</i>	
<b>SLUDGE RECEIVED (tonnes)</b>	
<b>SLUDGE TRANSFERRED (tonnes)</b>	
<b>EMISSION CONTROL AND REDUCTION MEASURES</b>	

<b>NATIONAL ENVIRONMENT AND PLANNING AGENCY (NEPA)</b>	
<b>POLLUTION REGISTER</b>	
<b>FACILITY POLLUTION PREVENTION AND RELEASE INFORMATION</b>	
	<b>Reporting Year</b>
<b>Overview Report</b>	
<b>POLLUTION PREVENTION AND ENERGY CONSERVATION ACTIVITIES</b> <i>(include all activities aimed at reducing carbon footprint, use of renewables)</i>	
<b>WATER CONSERVATION ACTIVITIES</b>	

<b>NATIONAL ENVIRONMENT AND PLANNING AGENCY (NEPA)</b>	
<b>POLLUTION REGISTER</b>	
<b>FACILITY POLLUTION PREVENTION AND RELEASE INFORMATION</b>	
	<b>Reporting Year</b>
<b>Overview Report</b>	
<b>COMMUNITY ACTIVITIES</b>	
<b>ECOLOGICAL ASSETS AND SOURCE WITHIN 5 km or URBAN AREA</b>	

**NATIONAL ENVIRONMENT AND PLANNING AGENCY (NEPA)  
POLLUTION REGISTER**

**FACILITY POLLUTION PREVENTION AND RELEASE INFORMATION**

**Reporting Year**

**Overview Report**

**ON SITE**



<b>NATIONAL ENVIRONMENT AND PLANNING AGENCY (NEPA)</b>	
<b>POLLUTION REGISTER</b>	
<b>FACILITY POLLUTION PREVENTION AND RELEASE INFORMATION</b>	
	<b>Reporting Year</b>
<b>Overview Report</b>	
<b>OFF SITE (WITHIN 5 km)</b>	
<b>MOST SIGNIFICANT ENVIRONMENTAL ASPECTS</b>	

**NATIONAL ENVIRONMENT AND PLANNING AGENCY (NEPA)  
POLLUTION REGISTER**

**FACILITY POLLUTION PREVENTION AND RELEASE INFORMATION**

**Reporting Year**

**Overview Report**

**ENVIRONMENTAL SETTING**

<b>NATIONAL ENVIRONMENT AND PLANNING AGENCY (NEPA)</b>	
<b>POLLUTION REGISTER</b>	
<b>FACILITY POLLUTION PREVENTION AND RELEASE INFORMATION</b>	
	<b>Reporting Year</b>
<b>Overview Report</b>	

## Appendix 4: Template of Detailed PRTR Facility Report

NATIONAL ENVIRONMENT AND PLANNING AGENCY (NEPA) POLLUTION REGISTER						
FACILITY POLLUTION PREVENTION AND RELEASE INFORMATION						
Reporting Year		Summary Report				
Facility Name:						
Address						
Address1						
Address2						
Parish						
Location		Latitude		JAD 2001		
Location		Longitude				
Public Contact:						
Public Contact (Phone):				Fax:		
Public Contact Email:						
Web Address:						
Number of Employees:						
Main Activities:						
International System for Industrial Classification (ISIC) Code(s)						
<b>Reporting Year</b>		<b>20XX</b>				
<b>Pollutant/Material</b>		<b>POLLUTANT RELEASES (tonnes)*#</b>			<b>% Compliance with applicable emission or effluent standard or guideline</b>	
	<b>Air</b>	<b>Water*</b>	<b>Land</b>	<b>Air</b>	<b>Water*</b>	<b>Land</b>
Ammonia						
Carbon dioxide						
Carbon monoxide						
Chrysene						
Copper						
Formaldehyde						
Methane						
Nitrogen oxides (NOx)						
Nitrous oxide (N2O)						
NM VOC						
Particulate Matter						
Particulate Matter (2.5 um diameter,						

<b>NATIONAL ENVIRONMENT AND PLANNING AGENCY (NEPA) POLLUTION REGISTER</b>						
<b>FACILITY POLLUTION PREVENTION AND RELEASE INFORMATION</b>						
<b>Reporting Year</b>						
filterable)						
Sulphur dioxide						
Toluene						
Total non-methane organic compounds (TNMOC)						
Reporting Year						
<b>Pollutant/Material</b>	<b>POLLUTANT RELEASES (tonnes)*#</b>			<b>% Compliance with applicable emission or effluent standard or guideline</b>		
	Air	Water*	Land	Air	Water*	Land
Treated Sewage and Trade Effluent						
Biological Oxygen Demand (BOD)						
Chemical Oxygen Demand (COD)						
Faecal Coliform						
Nitrate						
Oil & Grease						
Phosphate						
Solid Waste (Filter Mud)						
Sulphate						
Total suspended solids (TSS)						
Waste Oil						
*Values are preliminary estimates based on estimated flows. Analytical data may not represent loadings at point of discharge.						
# Values in tonnes except for faecal and total coliform in MPN/100 mL. Values for water include liquid releases to surface, salt and underground water bodies, to land and transfers off site. Releases to land include amounts stored on site and off site. A blank value means that no release estimate is required for that medium (air, water or land) and so the % compliance is shown as NA for that medium. There are no standards or guidelines for the following: greenhouse gases (carbon dioxide, nitrous oxide and methane) released to air and the flows of trade effluent and sewage effluent released to water.						
Each facility is required to make a certain number of measurements each year. The percentage of compliance with emission standards/guidelines or effluent standards is based on the number of measurements that are below the standard and the number of measurements required.						
Note: The P3RTR Register consists of substances that have a wide range of toxicities						

<b>NATIONAL ENVIRONMENT AND PLANNING AGENCY (NEPA) POLLUTION REGISTER</b>	
<b>FACILITY POLLUTION PREVENTION AND RELEASE INFORMATION</b>	
<b>Reporting Year</b>	
and environmental impacts. A small number may not necessarily imply an insignificant impact, for example, a small emission of a highly toxic substance may be of more concern than a larger emission of a substance of relatively lower toxicity.	
<b>PRE-TREATMENT</b> <i>(indicate how floatables are disposed, quantities and types)</i>	
<b>SLUDGE RECEIVED</b> <b>(tonnes)</b>	
<b>SLUDGE TRANSFERRED</b> <b>(tonnes)</b>	
<b>EMISSION CONTROL AND REDUCTION MEASURES</b>	
<b>POLLUTION PREVENTION AND ENERGY CONSERVATION ACTIVITIES</b> <i>(include all activities aimed at reducing carbon footprint, use of renewables)</i>	

<b>NATIONAL ENVIRONMENT AND PLANNING AGENCY (NEPA) POLLUTION REGISTER</b>	
<b>FACILITY POLLUTION PREVENTION AND RELEASE INFORMATION</b>	
<b>Reporting Year</b>	
<b>WATER CONSERVATION ACTIVITIES</b>	
<b>COMMUNITY ACTIVITIES</b>	

<b>NATIONAL ENVIRONMENT AND PLANNING AGENCY (NEPA) POLLUTION REGISTER</b>	
<b>FACILITY POLLUTION PREVENTION AND RELEASE INFORMATION</b>	
<b>Reporting Year</b>	
<b>ECOLOGICAL ASSETS AND SOURCE WITHIN 5 km or URBAN AREA</b>	
ON SITE	



<b>NATIONAL ENVIRONMENT AND PLANNING AGENCY (NEPA) POLLUTION REGISTER</b>	
<b>FACILITY POLLUTION PREVENTION AND RELEASE INFORMATION</b>	
<b>Reporting Year</b>	
OFF SITE (WITHIN 5 km)	
<b>MOST SIGNIFICANT ENVIRONMENTAL ASPECTS</b>	
<b>ENVIRONMENTAL SETTING</b>	

<b>NATIONAL ENVIRONMENT AND PLANNING AGENCY (NEPA) POLLUTION REGISTER</b>	
<b>FACILITY POLLUTION PREVENTION AND RELEASE INFORMATION</b>	
<b>Reporting Year</b>	
Reporting Year	

# Appendix 5: Template of the Quarterly/Annual Industrial Sludge Report

**THE NATURAL RESOURCES CONSERVATION AUTHORITY ACT  
THE NATURAL RESOURCES CONSERVATION AUTHORITY  
(Wastewater & Sludge) Regulations, 2013**

QUARTERLY AND ANNUAL INDUSTRIAL SLUDGE REPORTING  
FORM

1. Date: _____ Yyyy/mm/dd	2. Reporting Year: _____	3. Date Received _____ yyyy/mm/dd
------------------------------	--------------------------	---

4. Name, location and permit and licence numbers for the facility

Name \_\_\_\_\_ of  
Plant: \_\_\_\_\_

—  
Location \_\_\_\_\_ of  
Plant: \_\_\_\_\_

NRCA Permit No.: \_\_\_\_\_ NEPA \_\_\_\_\_ Licence  
No.: \_\_\_\_\_

5. Quarterly and Annual release of industrial sludge

Period	Type of sludge (Include description of types A, B C etc)	Amount of sludge generated in period (tonne)	Stored on Site at end of period (tonne)	Transferred off-site during period (tonne)	Other (specify)
Q1	A				
Q2	A				
Q3	A				
Q4	A				
Q1	B				
Q2	B				
Q3	B				

Q4	B				
Q1	C				
Q2	C				
Q3	C				
Q4	C				
<b>Repeat groups of four rows in the report for each additional type of sludge for the quarterly amounts</b>					
Year	A				
Year	B				
Year	B				
<b>Repeat one rows for each additional type of sludge for the annual amounts</b>					

6. Description of Sludge types (A, B, C etc)

7. Transfer of Sludge Off-Site

<b>Period</b>	<b>Type of Sludge</b>	<b>Date transfer</b>	<b>Amount transferred</b>	<b>Recipient</b>	<b>Address of Recipient (Destination) of Sludge</b>
<b>Add rows as needed for each transfer date</b>					

Regulatory Inspections/Visits

NRCA: Yes \_\_\_\_ No. \_\_\_\_

EHU: Yes \_\_\_\_ No. \_\_\_\_

List any operational problems and or equipment failures including periods of power outages and maintenance:

Date	Nature of problem	Duration
_____	_____	_____
_____	_____	_____
_____	_____	_____
_____	_____	_____
_____	_____	_____

Comments:

\_\_\_\_\_  
\_\_\_\_\_  
\_\_\_\_\_  
\_\_\_\_\_

\_\_\_\_\_  
Plant Operator Signature

\_\_\_\_\_  
Date

\_\_\_\_\_  
Owner Signature

\_\_\_\_\_  
Date

# Appendix 6: Summary Table for Load Calculation

All Load Values are in kg

		A Load Discharged									B Beneficial Use Load			C Net Load Subtract each of Column B from corresponding column in A									
Month	Total Monthly Flow m <sup>3</sup>	BOD <sub>5</sub>	TSS	N	P	COD	F. coli.	Oil & Grease	Heavy Metals	Total Heavy Metals	BOD <sub>5</sub>	N	P	BOD <sub>5</sub>	TSS	N	P	COD	F. coli.	Oil & Grease	Heavy Metals	Total Heavy Metals	
JAN																							
FEB																							
MAR																							
APR																							
MAY																							
JUN																							
JUL																							
AUG																							
SEP																							
OCT																							
NOV																							
DEC																							